



# SERIES TN451, TT451, TN601, AND TT601

## TOP NOTCH SYSTEMS

---

### NOTE

THE INSTALLATION DETAILS FOUND IN THIS PACKAGE ARE GENERIC AND ARE FOR REPRESENTATION ONLY WITH THE INTENT OF GIVING THE INSTALLATION TEAM A VISUAL REPRESENTATION AS TO HOW THE ASSEMBLIES TYPICALLY INSTALL. THE SHOP SUBMISSION DRAWINGS AND DETAILS ARE THE GOVERNING DOCUMENTS AND AS SUCH THIS PACKAGE IS TO BE USED ONLY AS A RESOURCE

FOLLOW SEALANT MANUFACTURERS' RECOMMENDATIONS FOR USE AND APPLICATION OF ALL STRUCTURAL SILICONE SEALANT AND WEATHER SEAL SILICONE SEALANT.

**CUSTOMER/PROJECT QUALITY ASSURANCE PROCEDURES ARE SEPARATE DOCUMENTS AND ARE TO BE FOLLOWED IN CONJUNCTION WITH THIS MANUAL.**

11M0212\_REV\_A\_11.21

# HANDLING, STORAGE, AND PROTECTION OF ALUMINUM

The following precautions are recommended to protect the material against damage. Following these precautions will help ensure early acceptance of your products and workmanship.

## **HANDLE CAREFULLY.**

All aluminum materials at job site must be stored in a safe place, well removed from possible damage by other trades. Cardboard wrapped or paper interleaved materials must be kept dry.

## **CHECK ARRIVING MATERIALS.**

Check for quantity counts and keep records of where various materials are stored.

## **KEEP MATERIALS AWAY FROM WATER, MUD, AND SPRAY.**

Prevent cement, plaster, or other materials from damaging the finish.

## **PROTECT THE MATERIALS AFTER ERECTION.**

Protect erected frame with polyethylene or canvas splatter screen. Cement, plaster, terrazzo, other alkaline solutions, and acid based materials used to clean masonry are harmful to the finish. ***If any of these materials come in contact with the aluminum, immediately remove with water and mild soap.***

The rapidly changing technology within the architectural aluminum products industry demands that U.S. Aluminum reserve the right to revise, discontinue, or change any product line, specification, or electronic media without prior written notice.

**NOTE:** Dimensions in parentheses ( ) are millimeters unless otherwise noted.

[usalum.com](http://usalum.com)

V 2024-0927

Copyright © 2021 US Aluminum

All rights reserved.

™ ® Trademarks of US Aluminum and its affiliated companies or respective owners.

# GENERAL INSTALLATION NOTES

- 1. REVIEW CONTRACT DOCUMENTS.** Check shop drawings, installation instructions, architectural drawings and shipping lists to become thoroughly familiar with the project. The shop drawings take precedence and include specific details for the project. Note any field verified notes on the shop drawings prior to installing. The installation instructions are of a general nature and cover most conditions.
- 2. INSTALLATION.** All materials are to be installed plumb, level, and true.
- 3. INSTALLER QUALIFICATION.** The **Series TN451/TT451/TN601/TT601 Top Notch** systems are intended for fabrication, assembly, sealing, installation and glazing by professionals with appropriate knowledge and experience of the system(s) and their incorporation into various building conditions.
- 4. BENCH MARKS.** All work should start from bench marks and/or column lines as established by the architectural drawings and the general contractor with guaranteed accuracy. Working from these datum points and lines determine:
  - a) The plane of the wall in reference to offset lines provided on each floor.
  - b) The finish floor lines in reference to bench marks on the outer building columns.
  - c) Mullion spacing from both ends of masonry opening to prevent dimensional build-up of daylight opening.
- 5. FIELD WELDING.** All field welding must be adequately shielded to avoid any splatter on glass or aluminum. Results will be unsightly and/or structurally unsound. Advise general contractor and other trades accordingly. All field welds of steel anchors must receive touch-up paint (zinc chromate) to avoid rust.
- 6. SURROUNDING CONDITIONS.** Make certain that construction which will receive your materials is in accordance with the contract documents. If not, notify the general contractor in writing and resolve differences before proceeding with work.
- 7. ISOLATION OF ALUMINUM.** Aluminum to be placed in direct contact with uncured masonry or incompatible materials should be isolated with a heavy coat of bituminous paint. For steel reinforcement primer, use manufacturer's standard corrosion resistant primer, meeting or exceeding Sherwin Williams Kem Kromik® and ASTM D5894, 1008 Corrosion Resistance.
- 8. SEALANTS.** The fabrication and installation of a structural silicone-glazed (SSG) or wet glazed system requires more technical knowledge and experience than is required for a conventional pressure-glazed or dry glazed system. The glazing contractor should take all steps as outlined and required by the structural silicone sealant manufacturer, glass fabricator, framing manufacturer, and the project professional engineer of record as well as follow local building code requirements and industry best practices to ensure the proper installation and safe performance of the SSG system.

The glazing contractor for each project needs to ensure compliance with each step, including, but not limited to, design reviews, formal adhesion testing, formal compatibility testing, project specification compliance, validating procedures, field testing, and quality control validation of installed product and surrounding conditions.

Testing of component materials for use in a SSG or wet glazed system is mandatory to fulfill project specifications and warranty requirements and must be submitted by the glazing contractor to the structural silicone manufacturer. All materials that comprise the structural silicone joint, such as the framing system (with the job-specific finish) and job-specific glass must be tested by the structural silicone manufacturer for compatibility and adhesion. All other accessory materials in contact with the structural silicone, such as setting blocks, spacers, gaskets, sweeps, air seals and expansion joints, must also be submitted to the silicone sealant manufacturer for compatibility testing.

To ensure that nothing has changed in formulation or chemistry since the initial tests, subsequent testing during periodic time frames of the project is to be conducted to confirm continued acceptance of the material for use on the project.

To ensure the structural performance and integrity of the insulating glass unit (IGU), the glazing contractor must submit the project shop drawings to the glass fabricator to obtain approval for use of their product(s) in any 2, 3 or 4-sided SSG applications.

# GENERAL INSTALLATION NOTES CONT.

## Recommended guidelines for all installations:

Quality control procedures for field glazing are to be increased beyond those required for shop glazing. Job conditions will normally have dust, dirt, and other construction debris on the surfaces where structural silicone is to be applied. Great care should be exercised in cleaning and preparing these surfaces for silicone application. The recommendations of the silicone sealant manufacturer are to be strictly enforced and followed. The fabrication and installation of the SSG system and its components, whether shop or field glazed, should be governed by a quality control program, and all steps, procedures, and test reports should be documented throughout the project.

Prior to installation of any SSG system, refer to industry documents (e.g., AAMA Curtain Wall Design Guide Manual, ASTM C1401-14, and AAMA SSGDG-17) for detailed instructions and recommendations.

THE GLAZING CONTRACTOR ASSUMES FULL RESPONSIBILITY FOR ENSURING COMPLIANCE WITH THE ABOVE, AND ASSUMES FULL LIABILITY FOR ANY ISSUES ARISING FROM NONCOMPLIANCE.

9. **FASTENING.** Within the body of these instructions "fastening" means any method of securing one part to another or to adjacent materials. Only those fasteners used within the system are specified in these instructions. Due to the varying perimeter conditions and performance requirements, perimeter and anchor fasteners are not specified in these instructions. For perimeter and anchor fasteners refer to the shop drawings or consult the fastener supplier.
10. **BUILDING CODES.** Due to the diversity in state/provincial, local, and federal laws and codes that govern the design and application of architectural products, it is the responsibility of the individual architect, owner, and installer to assure that products selected for use on projects comply with all the applicable building codes and laws. U.S. Aluminum exercises no control over the use or application of its products, glazing materials, and operating hardware, and assumes no responsibility thereof.
11. **EXPANSION JOINTS.** Expansion joints and perimeter seals shown in these instructions and in the shop drawings are shown at normal size. Actual dimensions may vary due to perimeter conditions and/or difference in metal temperature between the time of fabrication and the time of installation. Gaps between expansion members should be based on temperature at time of installation.
12. **GLAZING PRACTICES.** The air and water performance of the **Series TN451/TT451/TN601/TT601 Top Notch** systems is directly related to the completeness and integrity of the installation process, including but not limited to the assembly seals of the framing joinery, the installed glazing gaskets, and the alignment of the framing joinery glazing plane. Before glazing, verify the glazing pocket width and glazing infill thickness, as both must be in tolerance to assure adequate edge pressure and to achieve the desired air and water performance levels. (In general, framing systems utilizing 1" insulating glass are designed to accommodate a thickness variance of +/- 1/32"). Note: Excessive pressure can cause glass breakage and/or IGU failure. Consult the glass manufacturer for their recommended edge pressure per lineal inch.

To achieve the designed and tested air and water performance, best practices include:

- Glazing gaskets should be cut 1/4" longer per foot, and lay flat, preferably for 24 hours
- Gaskets should be cut as single monolithic pieces and "crowded" during their installation to avoid corner gaps caused by post-installation relaxation
- The interior glazing gasket should be installed so as to avoid stretching, buckles, or tears
- Corners must be cut square, and at a slight angle when required to conform to the bevel on the intersecting gasket; sealed and butted together.
- Gasket corner joinery must also be crowded, and sealant applied onto the gasket contact frame surface and into gasket reglet raceway where applicable.
- Gasket corner seals are to be done just prior to installing glass, while the sealant is still wet and uncured, and ensure exterior gaskets are installed so as to place the glass into it's final in service condition and allow the sealant to conform to optimum configuration. Note: If the sealant cures prior to glazing, the cured sealant could create excessive edge pressure onto the glass and has the potential to cause glass breakage.
- The glass must be checked for squareness, size dimension, and thickness along the edges paying attention to any variances from center edge to corner edge
- Check the placement of the installed glass and verify there is proper edge bite into the pocket, and proper edge clearance from framing elements

# GENERAL INSTALLATION NOTES CONT.

## Recommended guidelines for all installations:

After sealant has set and a representative amount of the wall has been installed and glazed (250 square feet or more) run a water hose test in accordance with AAMA 501.2 specifications to check installation. On large projects the hose test should be repeated during the glazing operation. Consult and follow NGA's GANA Manual and FGMA Glazing Manual for proper glazing technique and procedure.

13. **COORDINATION WITH OTHER TRADES.** Coordinate with the general contractor any sequence with other trades which offset curtain wall installation (i.e. fire proofing, back-up walls, partitions, ceilings, mechanical ducts, converters, etc.).
14. **CARE AND MAINTENANCE.** Final cleaning of exposed aluminum surfaces should be done in accordance with AAMA 609.1 for anodized aluminum and 610.1 for painted aluminum.

# TECHNICAL DATA

The Top Notch Systems offer a shallow face reveal that creates a flush exterior appearance. These systems are designed for labor saving stacking type installations that requires glazing from the interior. Series **TN451** and **TT451** utilize Top Load Gaskets. Series **TN601** and **TT601** utilize wedge-type molded corner exterior sponge gaskets for superior air and water performance. Internal water deflectors at intermediate horizontal to vertical intersections allow infiltrated water to be drained into a continuous sill gutter and weeped to the exterior. Vertical mullions for structural silicone glazing are also available. The Top Notch Systems are designed for fixed horizontal window wall or punched opening applications.

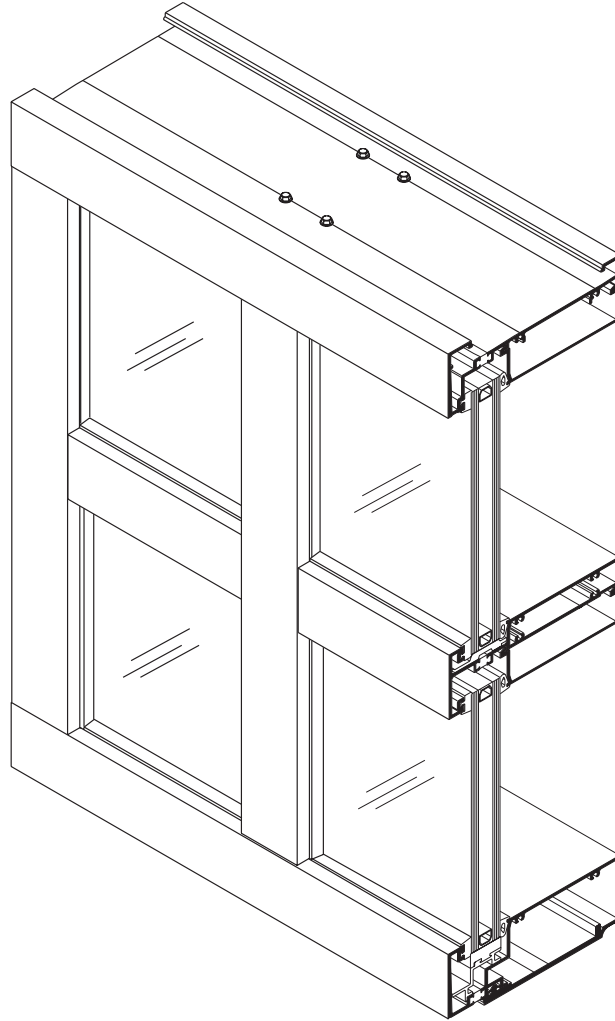

SERIES	WIDTH	HEAD/SILL DEPTH	GLAZING INFILL	APPLICATION
<b>TN451/TT451</b>	2-1/4" (57.2)	4-1/2" (114.3)	1" (25)	Horizontal Interior Glazed Window Walls for Low to mid-rise buildings.
<b>TN601/TT601</b>	2-1/4" (57.2)	6" (152.4)	1" (25)	

GLASS SIZES*	
GLASS WIDTH AND GLASS HEIGHT	= DAYLIGHT OPENING + 7/8" (22.2)

\* These formulae do not take into account glass tolerances. Consult glass manufacturer before ordering glass.

[usalum.com](http://usalum.com)

V 2024-0927

Copyright © 2021 US Aluminum

All rights reserved.

™ ® Trademarks of US Aluminum and its affiliated companies or respective owners.

# SITE PREPARATION

## BEFORE INSTALLATION

1. Review and measure the opening.
2. Verify rough window opening size 1/2" (12.7) clearance in both width and height to the window. Verify framing is plumb, straight, and true around window opening. Measure opening at each end and at center vertically and horizontally. Make corrections to openings as required. Measure opening diagonally to check squareness. Chip concrete high points to flush and rounded corners to square.

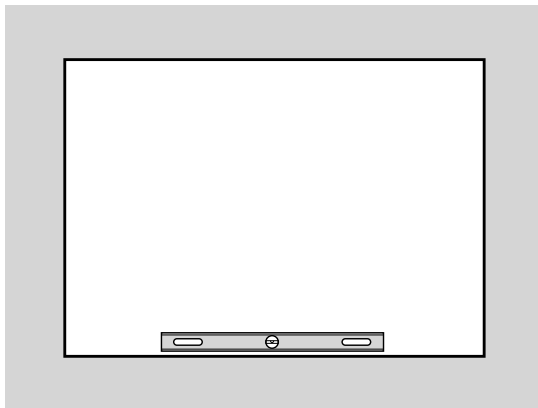

LEVEL

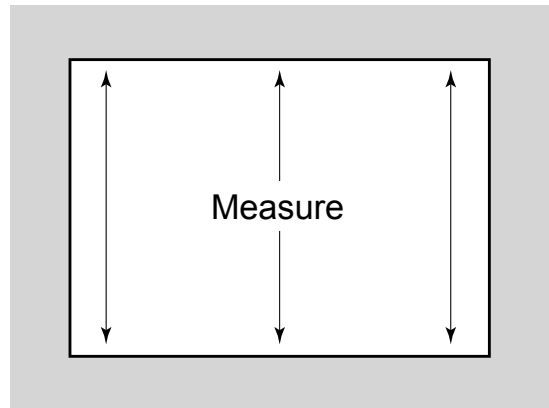

VERTICAL DIMENSION

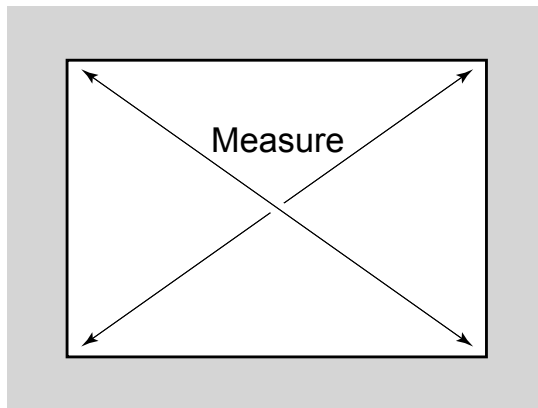

SQUARE

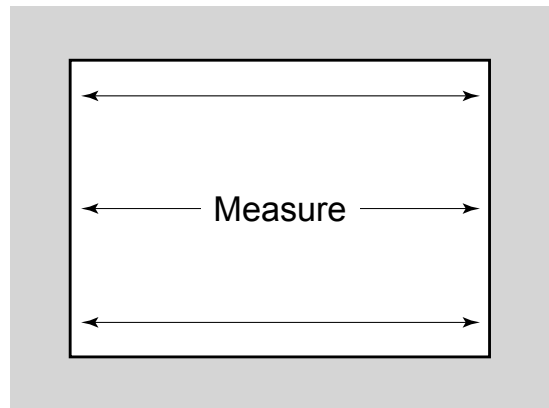

HORIZONTAL DIMENSION

# TOP NOTCH SYSTEM INSTALLATION INSTRUCTIONS

Frames may be shop fabricated, assembled and shipped to job site in units. System features continuous head and sill members with vertical to head and sill screw race joinery and is interior glazed.

## FRAME FABRICATION AND ASSEMBLY

Allow 3/8" (9.5) minimum clearance for shimming and caulking around perimeter. Extra clearance may be necessary to accommodate building tolerances. Expansion mullions must be used in long run elevations to allow for thermal movement.

1. Measure rough opening to determine frame height and width dimensions.
2. Cut members to size. **See DETAIL A.**

<b>Head and Sills:</b>	Frame Width = Rough opening minus 3/4" (19.1)
<b>Intermediate Horizontals:</b>	D.L.O.
<b>Jams and Verticals:</b>	Frame Height minus 1-1/8" (28.5)
<b>Horizontal Glass Stops:</b>	D.L.O. minus 1/32" (0.8)
<b>Head and Sill Anchors:</b>	Refer to shop drawings for size and placement.

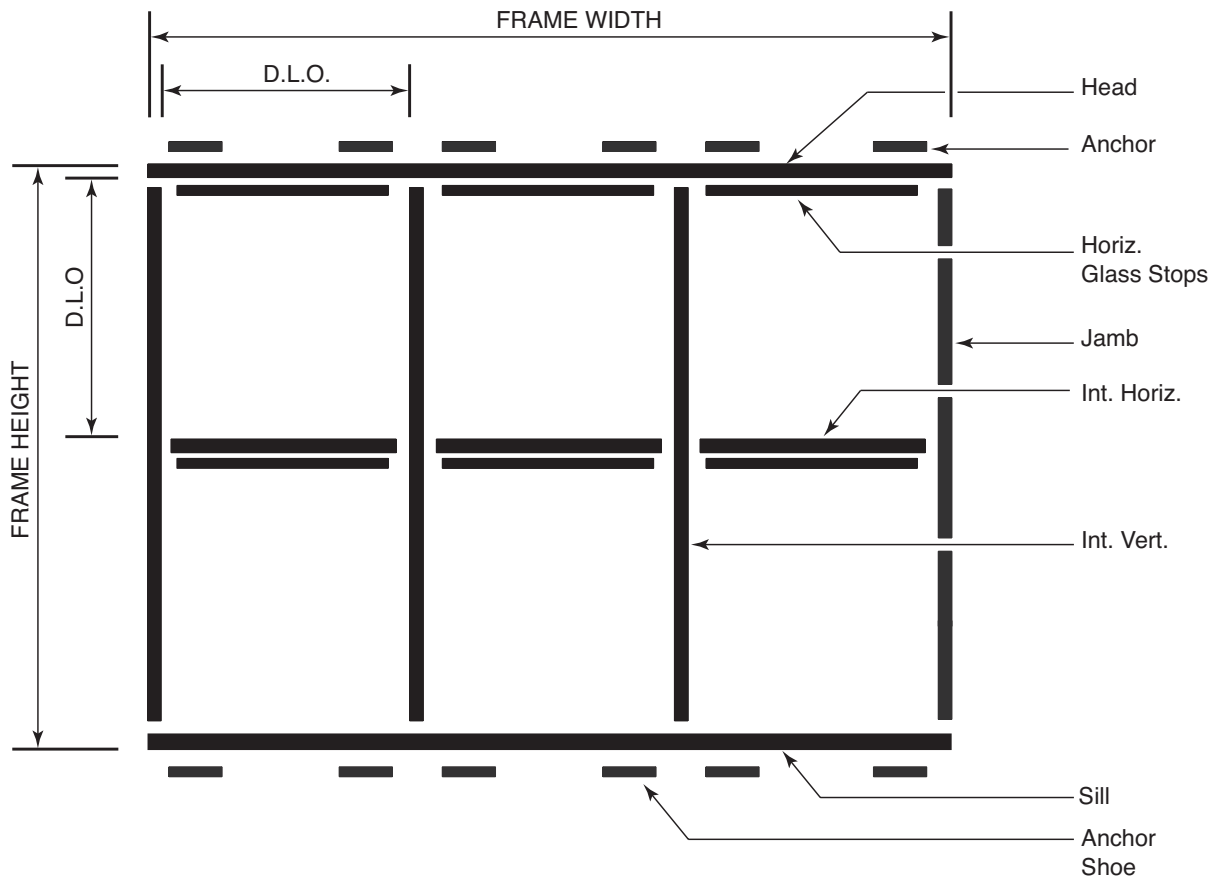

**DETAIL A**



# SERIES TN451, TT451, TN601, AND TT601 TOP NOTCH

## TYPICAL DETAILS FOR 1" (25) GLAZING

**NOTE:** Part numbers shown are available in 24' (7.3 m) stock lengths. Visit: [usalum.com](http://usalum.com) for more information.

**Never allow two shallow pockets to face each other.**  
Plan units accordingly. **See DETAIL B.**

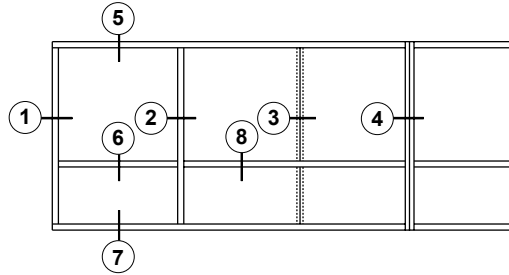

TYPICAL ELEVATION

Series TN451, TT451  
Series TT451 shown

Part numbers ending in "T" are **Thermally Broken**. These part numbers are in bold.

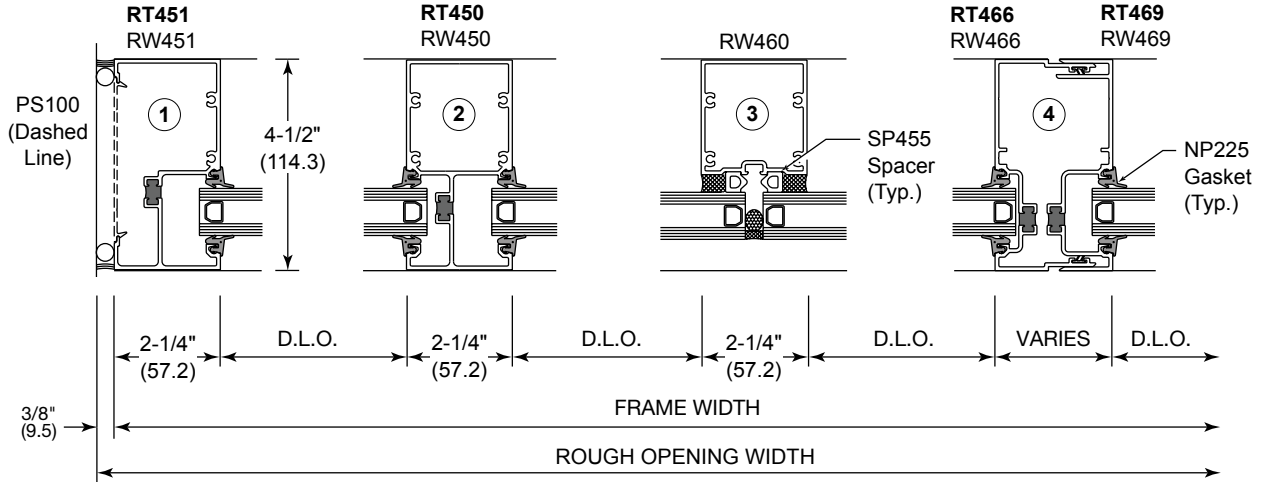

DETAIL B

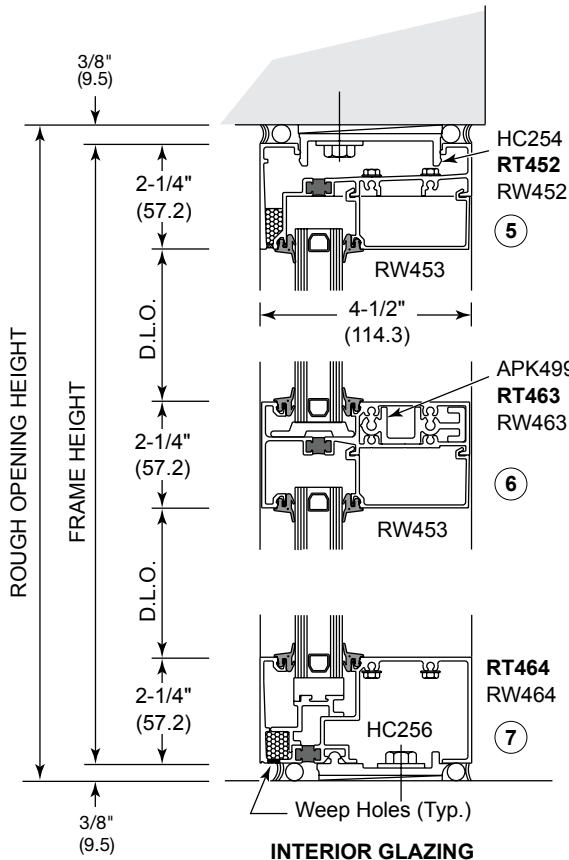

INTERIOR GLAZING

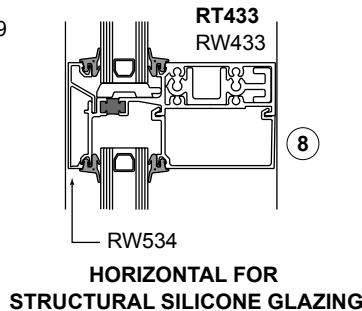

HORIZONTAL FOR STRUCTURAL SILICONE GLAZING

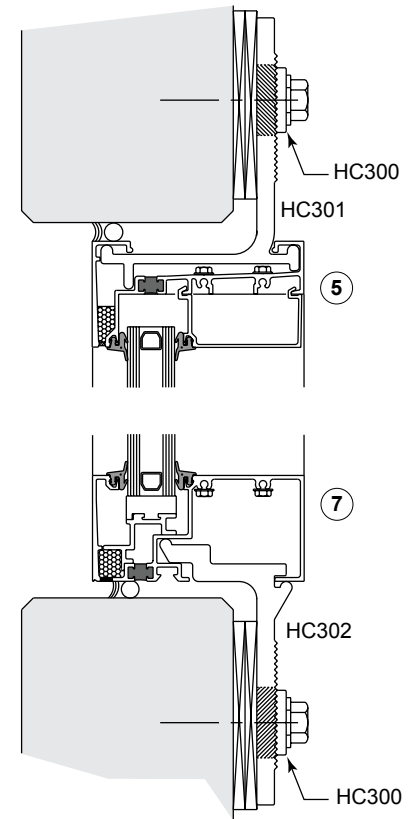

PRECAST ANCHOR CONDITION

NOT TO SCALE

[usalum.com](http://usalum.com)

V 2024-0927

Copyright © 2021 US Aluminum

All rights reserved.

™ ® Trademarks of US Aluminum and its affiliated companies or respective owners.

# SERIES TN451, TT451, TN601, AND TT601 TOP NOTCH

## TYPICAL DETAILS FOR 1" (25) GLAZING

**NOTE:** Part numbers shown are available in 24' (7.3 m) stock lengths. Visit: [usalum.com](http://usalum.com) for more information.

**Never allow two shallow pockets to face each other.**

Plan units accordingly. **See DETAIL C.**

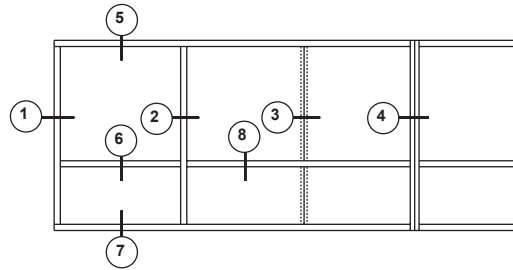

TYPICAL ELEVATION

Series TN601, TT601  
Series TT601 shown

Part numbers ending in "T" are **Thermally Broken**. These part numbers are in bold.

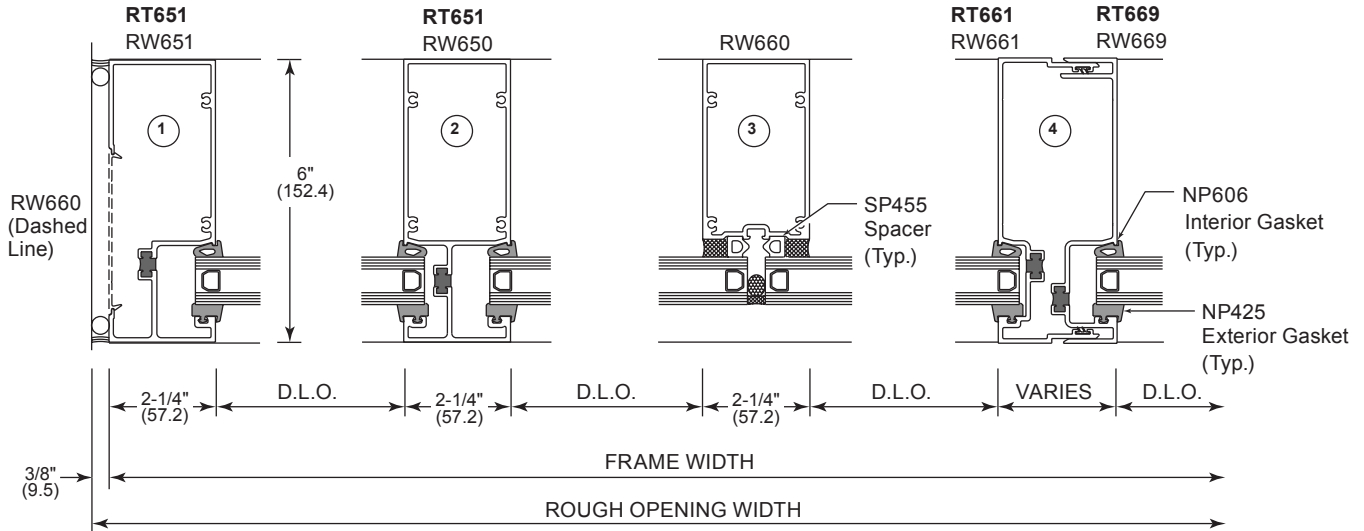

DETAIL C

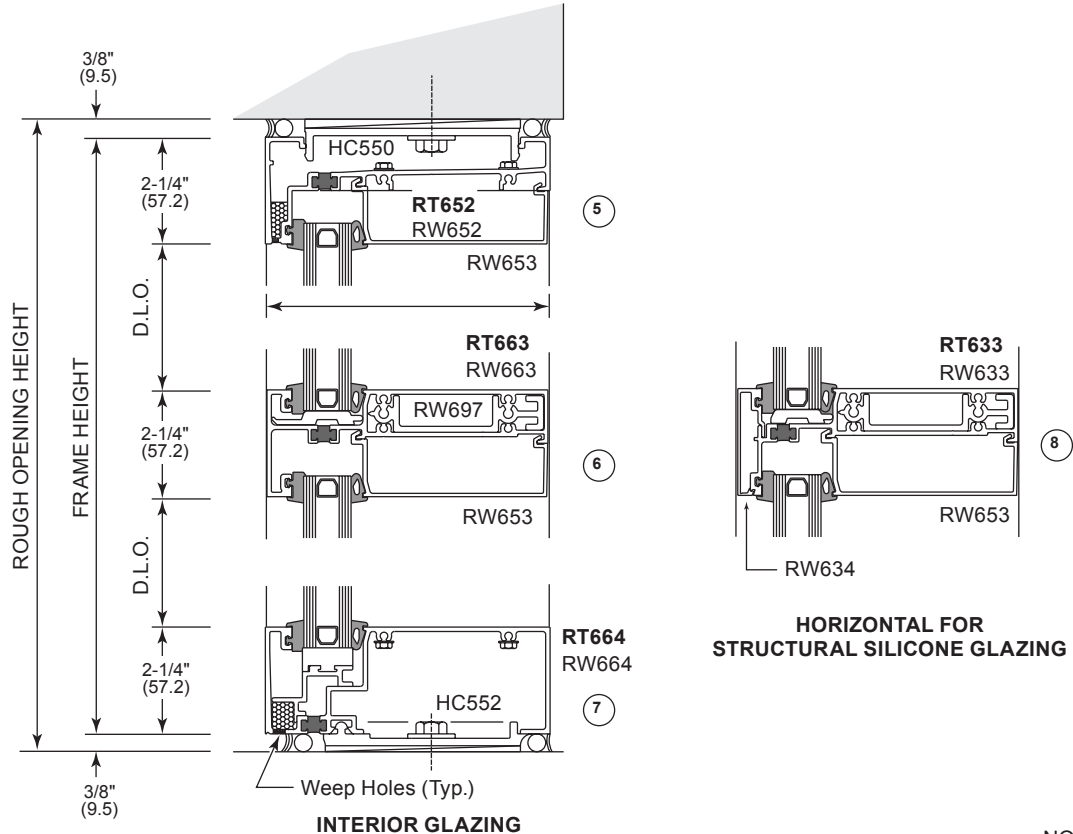

INTERIOR GLAZING

HORIZONTAL FOR STRUCTURAL SILICONE GLAZING

NOT TO SCALE

[usalum.com](http://usalum.com)

V 2024-0927

Copyright © 2021 US Aluminum

All rights reserved.

™ ® Trademarks of US Aluminum and its affiliated companies or respective owners.

# SERIES TN451, TT451, TN601, AND TT601 TOP NOTCH

## FRAME FABRICATION AND THE DRILL JIG

3. Mark the location of verticals on the head and sill members. Align edge of Drill Jig with marks and drill holes 1 through 6 according to system depth. **See DETAIL D.**

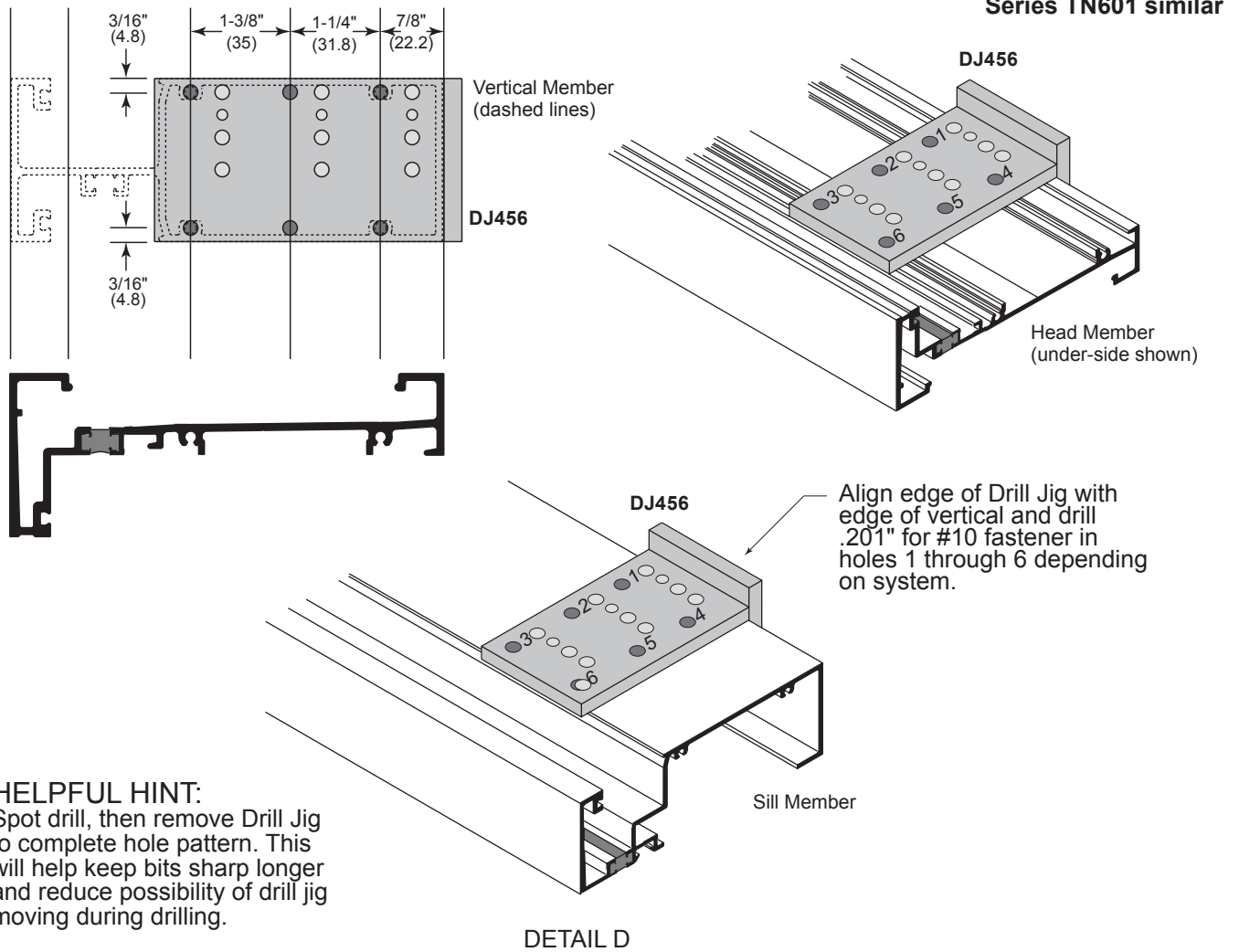

4. See shop drawings for exact anchor locations. Drill 7/8" (22.2) dia. access hole at "V" groove of head member. **See DETAIL E.**

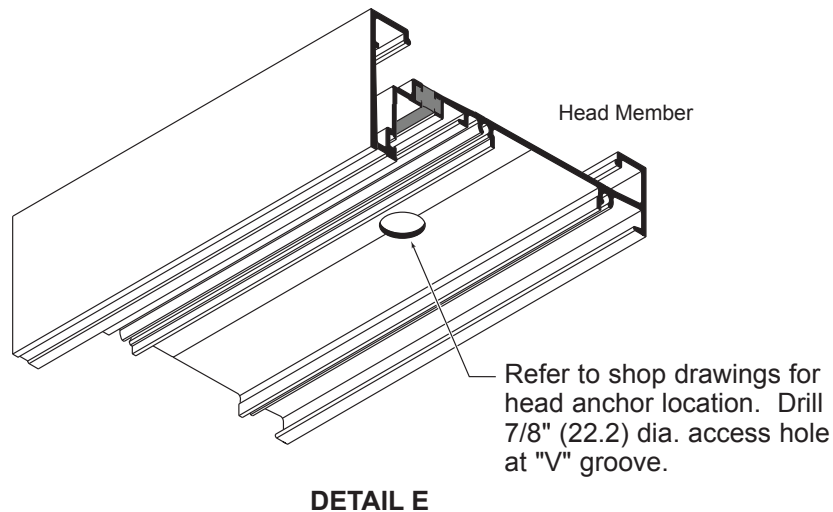

# SERIES TN451, TT451, TN601, AND TT601 TOP NOTCH

5. Mark the location at the top of each intermediate horizontal on the vertical members and drill holes for screw spline or shear block attachment. The use of drill jigs is recommended. See **DETAIL F**.

## HELPFUL HINT:

Spot drill, then remove Drill Jig to complete hole pattern. This will help keep bits sharp longer and reduce possibility of drill jig moving during drilling.

### Head

Align Jig with top of Vertical and drill holes "J" - "L" or holes "K" - "L" depending on system depth.

### Horizontal Mullions

Align Jig with top of Horizontal Mullions and drill holes "I", "H", and "G" depending on system depth for shear block attachment.

### Sill

Align Jig with bottom of Vertical and drill holes "A", "B" and "C" depending on system depth.

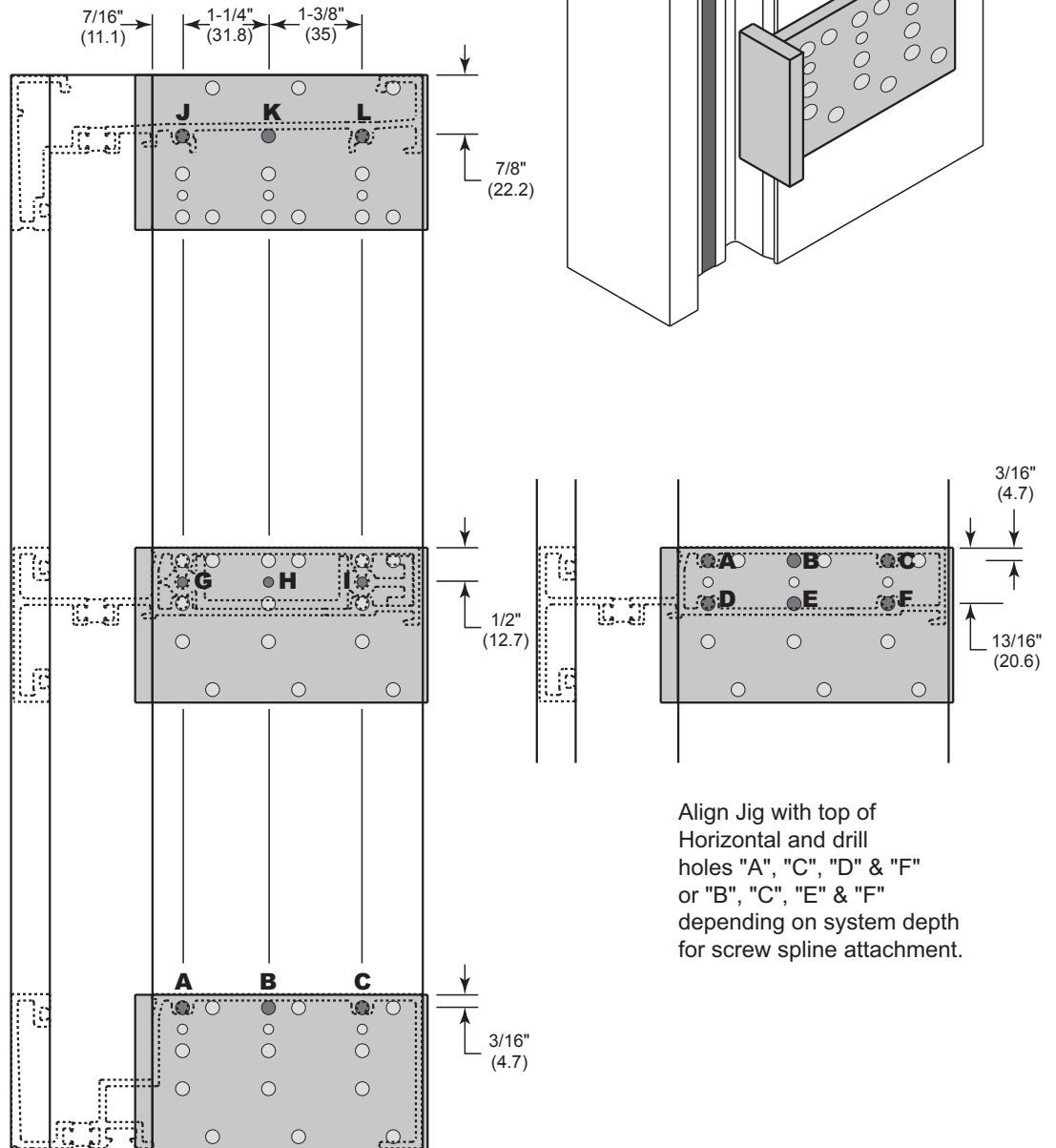

**DETAIL F**

[usalum.com](http://usalum.com)

V 2024-0927

Copyright © 2021 US Aluminum

All rights reserved.

™ ® Trademarks of US Aluminum and its affiliated companies or respective owners.

## SERIES TN451, TT451, TN601, AND TT601 TOP NOTCH

6. Measure 1" (25.4) from each end of horizontal member for shear block attachment hole. When using the 4-1/2" (114.3) system, line drill through "V" groove. For 6" (152.4) system, measure 1-3/8" (34.9) from back of horizontal and drill .201" dia. hole. See **DETAIL G**.

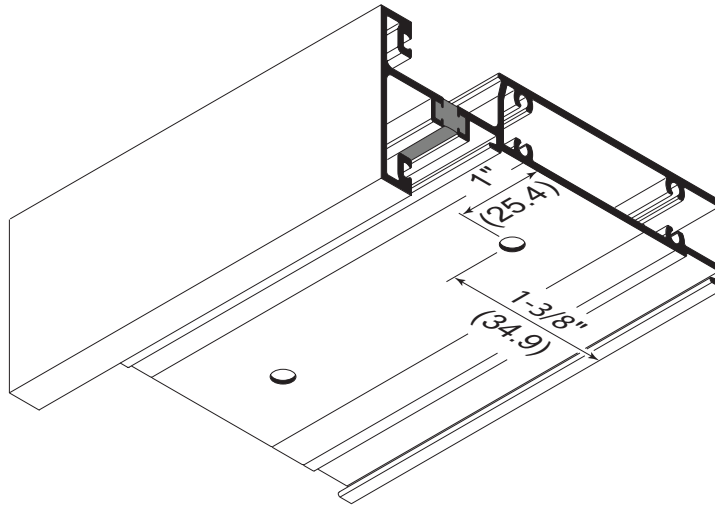

**DETAIL G**

7. Notch the top of all vertical members as shown below. See **DETAIL H**.  
**NOTE: Expansion mullions do not require notching at the top.**

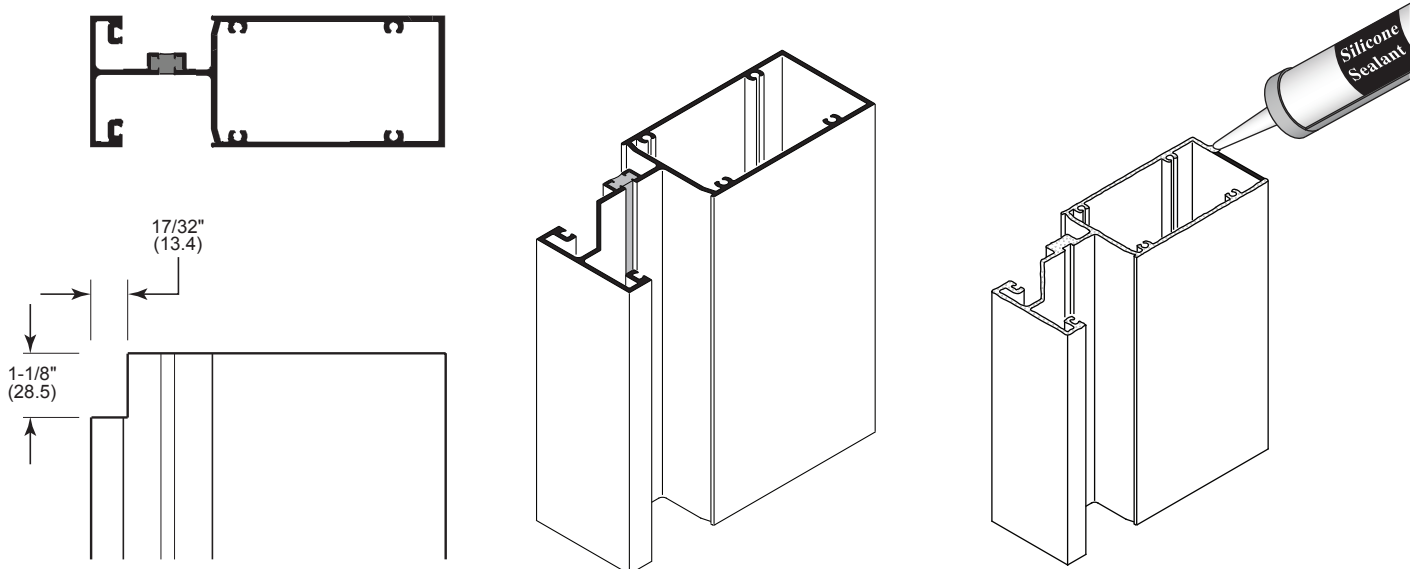

Notch top of Vertical member to clear Head Horizontal.

After notching top of Vertical, seal end completely with Silicone Sealant.

**DETAIL H**

[usalum.com](http://usalum.com)

V 2024-0927

Copyright © 2021 US Aluminum

All rights reserved.

™ ® Trademarks of US Aluminum and its affiliated companies or respective owners.

## SERIES TN451, TT451, TN601, AND TT601 TOP NOTCH

8. Drill weep holes in sill members as shown. See DETAIL I.

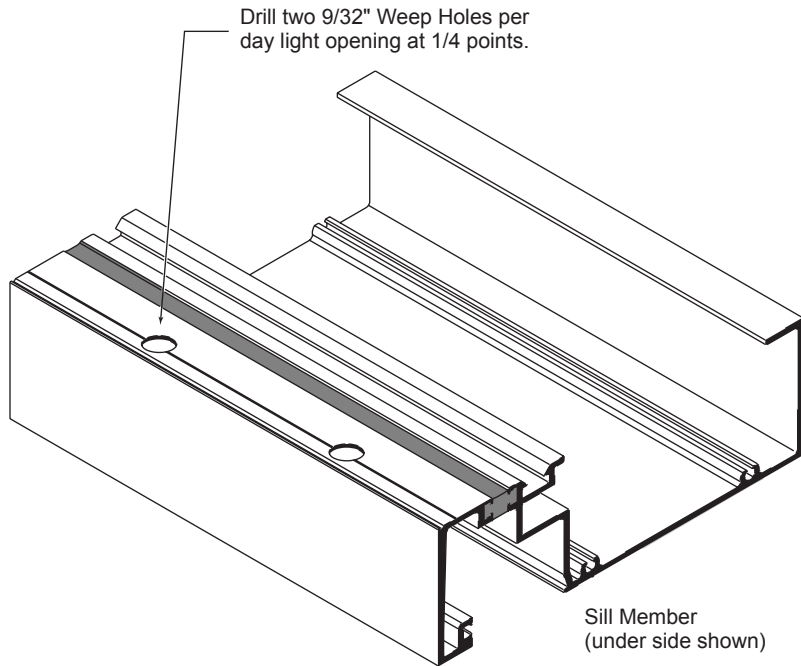

DETAIL I

## FRAME ASSEMBLY

1. Attach shear blocks to verticals as shown with two #10 x 2" Phillips Head Sheet Metal Screws (Part 10X2PHPSMS). See DETAIL J.

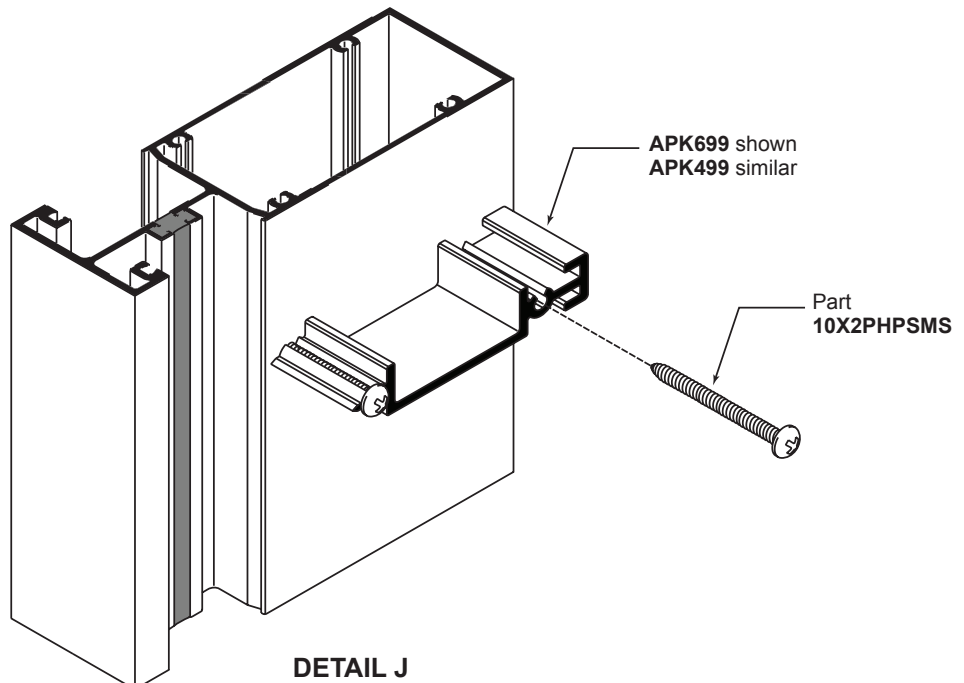

[usalum.com](http://usalum.com)

V 2024-0927

Copyright © 2021 US Aluminum

All rights reserved.

™ ® Trademarks of US Aluminum and its affiliated companies or respective owners.

## SERIES TN451, TT451, TN601, AND TT601 TOP NOTCH

2. Install End Dams to ends of head and sill members. Apply Silicone Sealant to both edges of head and sill members. Seal front portion of end dams and fasten with #8 x 3/8" Phillips Head Sheet Metal Screws (Part 8x38PHPSMS). Afterwards, seal over both sets of holes at head End Dam only. See **DETAIL K**.

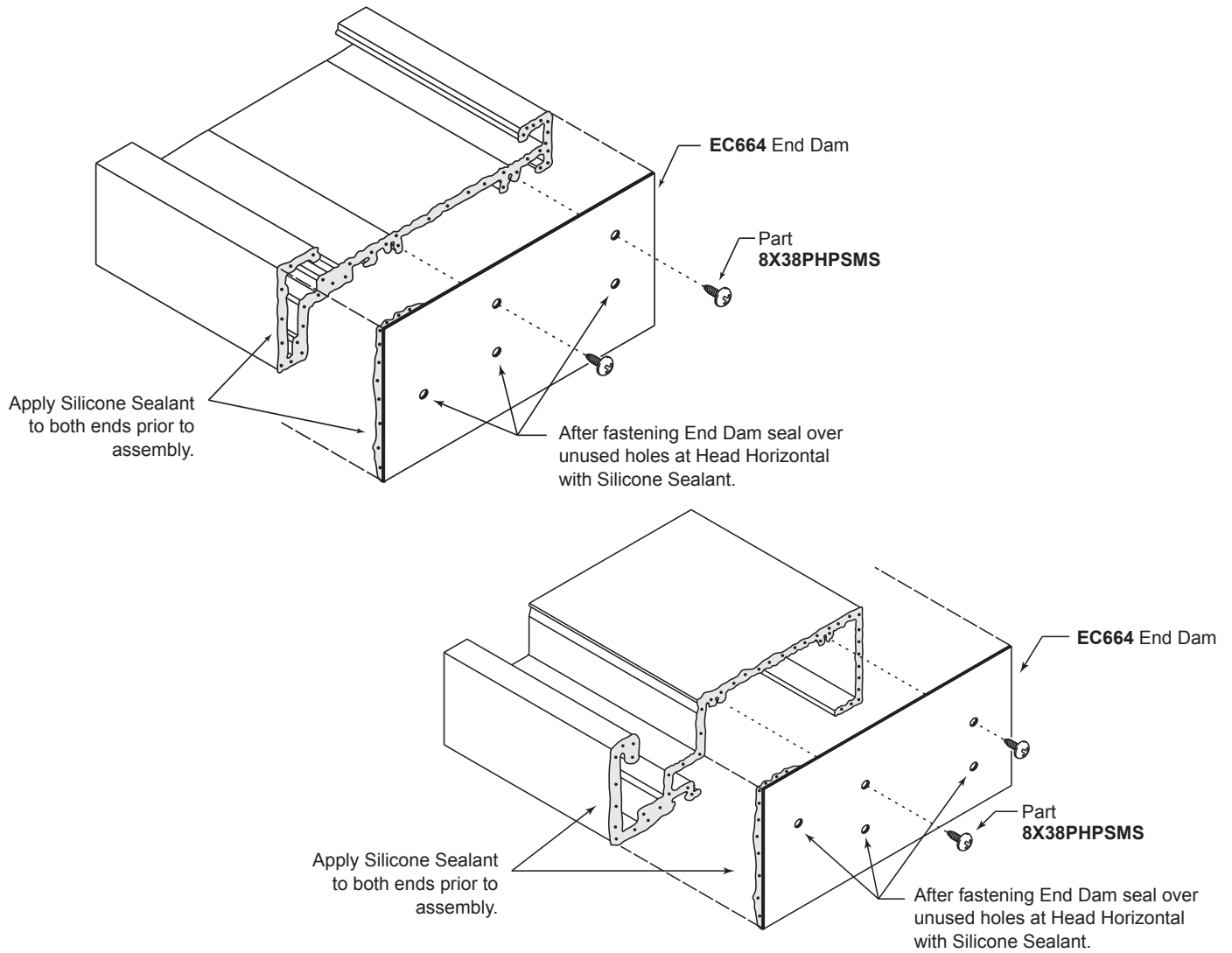

**DETAIL K**

3. Apply Silicone Sealant as shown to all Vertical members. See **DETAIL L**.

After notching top of Vertical, seal end completely with Silicone Sealant.

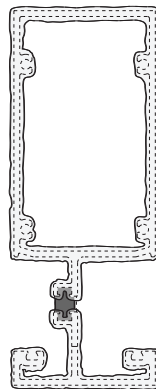

**DETAIL L**

[usalum.com](http://usalum.com)

V 2024-0927

Copyright © 2021 US Aluminum

All rights reserved.

™ ® Trademarks of US Aluminum and its affiliated companies or respective owners.

\*CRL items listed above or equivalent

## SERIES TN451, TT451, TN601, AND TT601 TOP NOTCH

- Punch  $3/16"$  (4.8) x  $3/8"$  (9.5) Weep Slot in head member at one per 12' stock length. Insert **UB625** Weep Baffle at all Weep Hole locations. See **DETAIL M**.

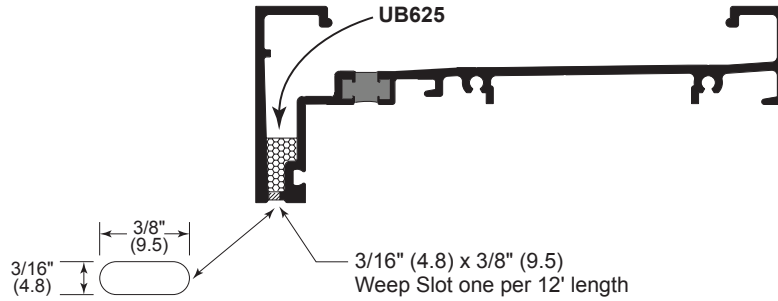

**DETAIL M**

- Align verticals with pre-fabricated holes in head and sill members. Fasten at each end with four #10 x 1-1/2" Phillips Head Sheet Metal Screws (Part **10x112PHPSMS**). See **DETAIL N**. Seal over screw heads with Silicone Sealant at head members.

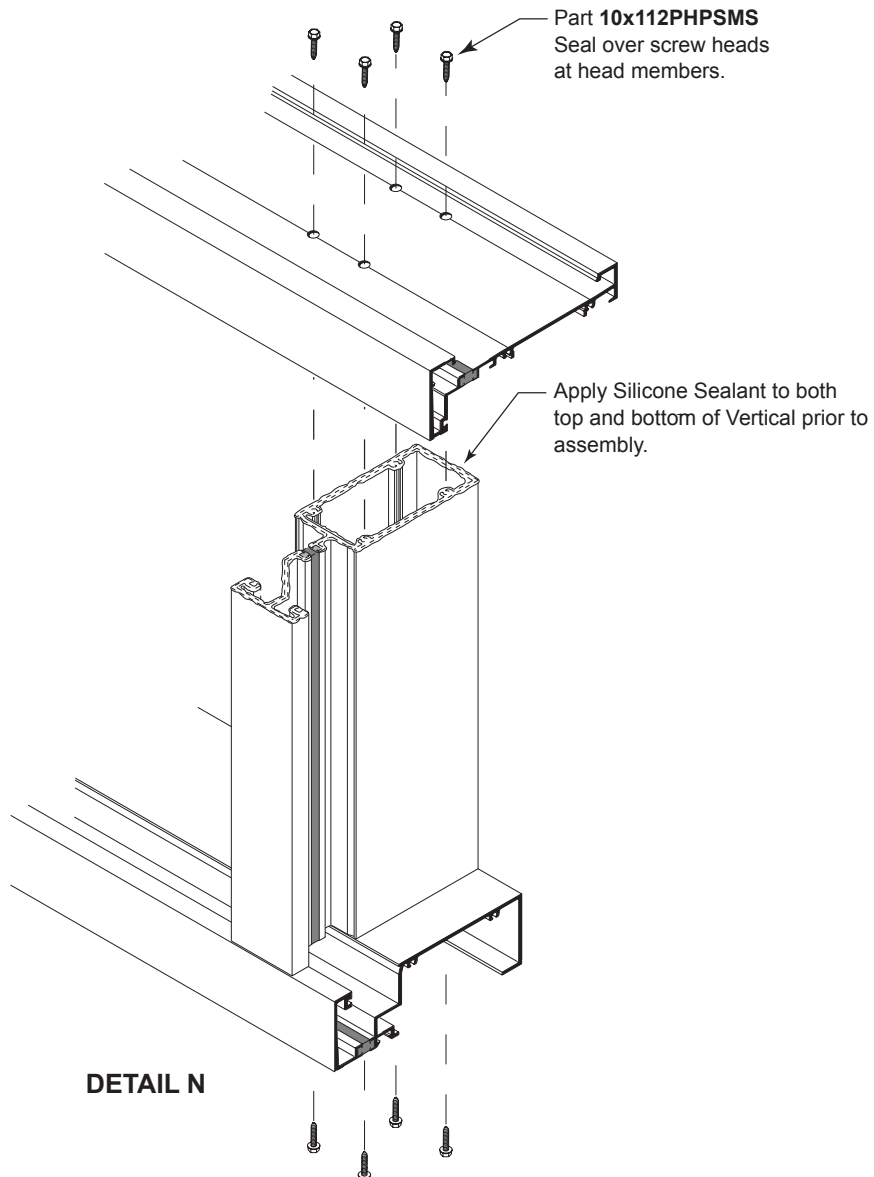

**DETAIL N**

[usalum.com](http://usalum.com)

V 2024-0927

Copyright © 2021 US Aluminum

All rights reserved.

™ ® Trademarks of US Aluminum and its affiliated companies or respective owners.



## SERIES TN451, TT451, TN601, AND TT601 TOP NOTCH

6. Seal both ends of intermediate horizontal members and fasten to verticals with #10 x 1/2" Phillips Head Sheet Metal Screw (Part 10X12PHPSMS). See **DETAIL O**.

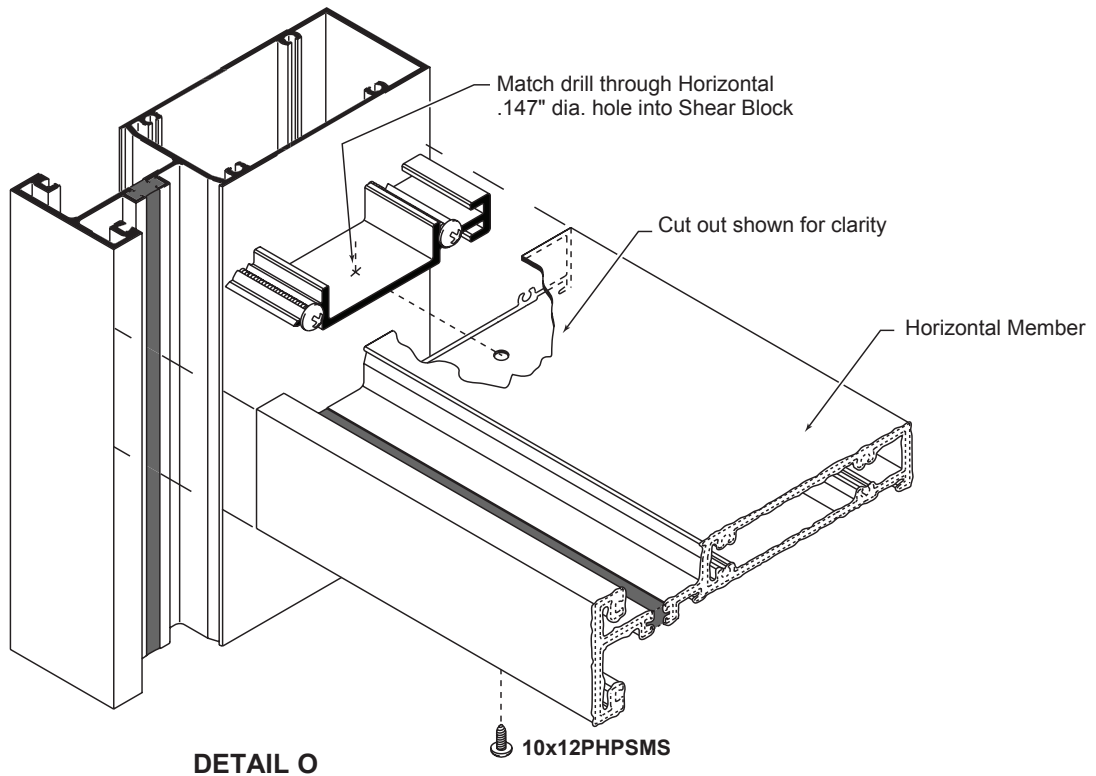

7. Install EVA foam to base of vertical as shown. Seal foam into place from inside of pocket to eliminate air infiltration. See **DETAIL P**.

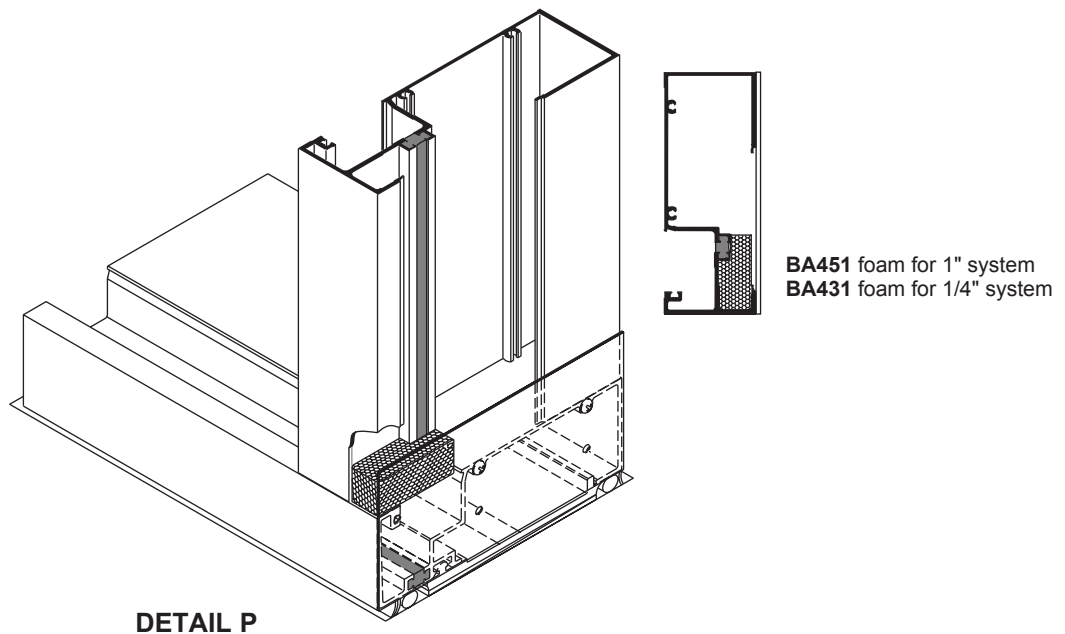

[usalum.com](http://usalum.com)

V 2024-0927

Copyright © 2021 US Aluminum

All rights reserved.

™ ® Trademarks of US Aluminum and its affiliated companies or respective owners.

## SERIES TN451, TT451, TN601, AND TT601 TOP NOTCH

8. Snap a chalk line in the location where the sill anchors will be installed. Refer to shop drawings for sill anchor size and location, along with bolt size and quantity. **See DETAIL Q.**

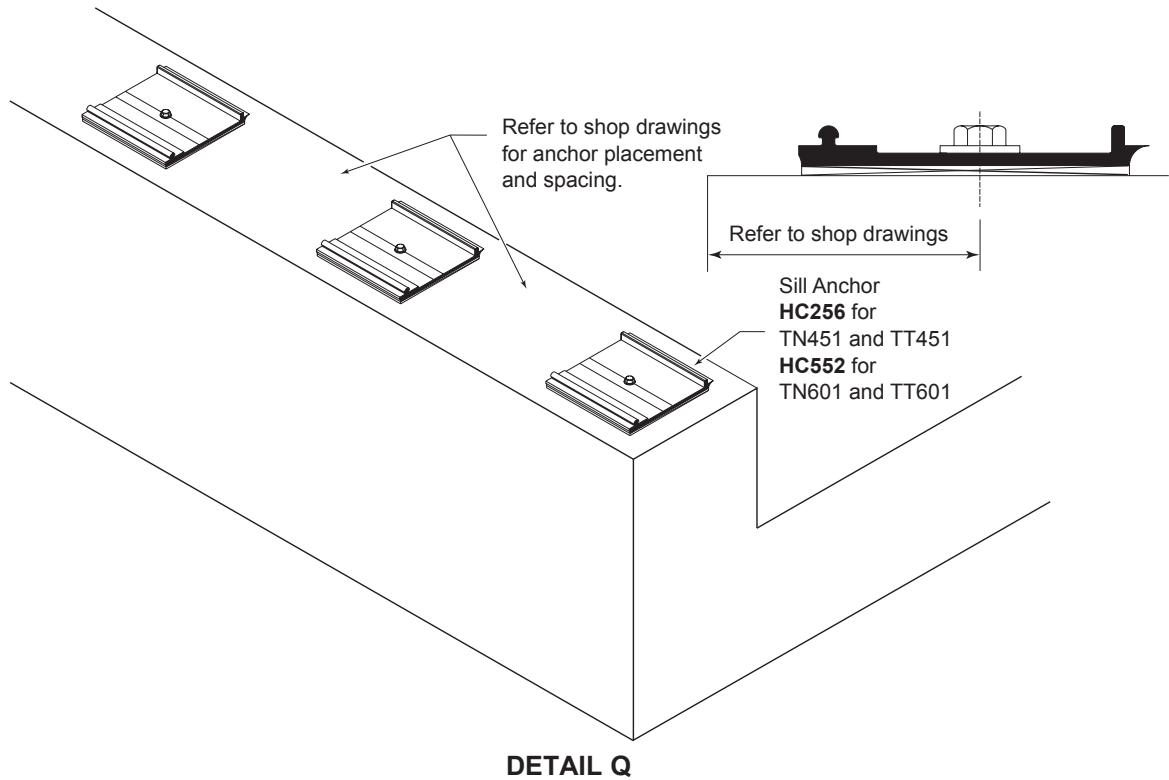

9. Install head anchor into head members at proper locations. Refer to shop drawings for anchors size and location and also bolt size and quantity. **See DETAIL R.**

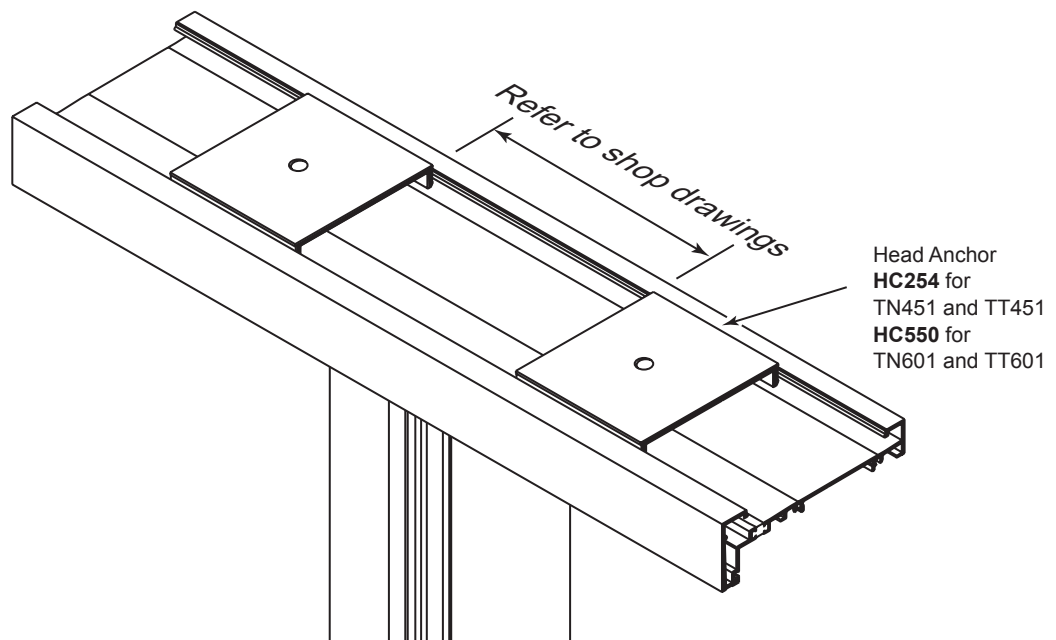

## FRAME INSTALLATION

1. Install frame into opening. Place frame on sill anchor and lean forward, center in opening, plumb, level and true. See **DETAIL S**.
2. Fasten head anchors through access holes in head members.
3. Insert **BA451** foam into access holes and apply sealant around entire edge of plug. See **DETAIL T**.  
**NOTE: BA451** is to be used for both 1" and 1/4" system.

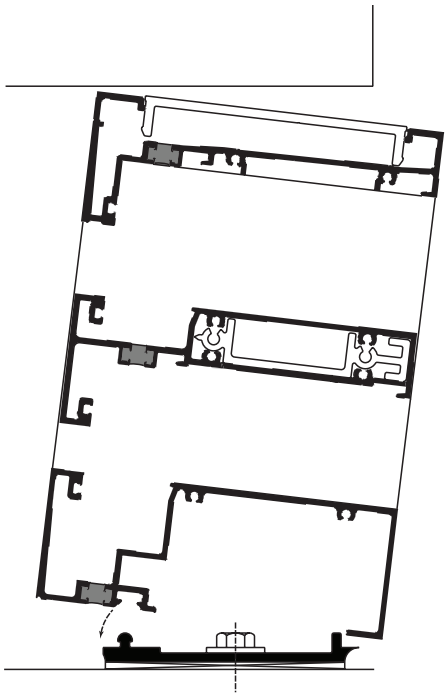

**DETAIL S**

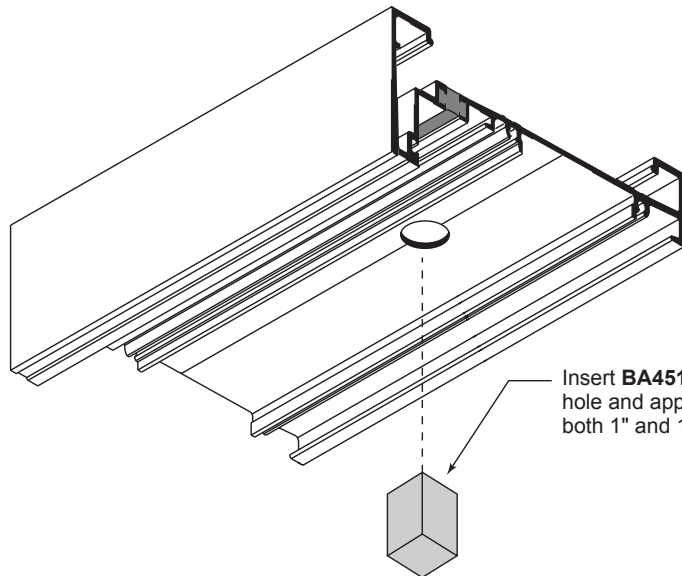

Insert **BA451** foam into access hole and apply sealant. Use for both 1" and 1/4" systems.

**DETAIL T**

4. Apply weather sealant for perimeter seal around entire frame taking caution not to seal over weep holes at the sill. See **DETAIL U**.

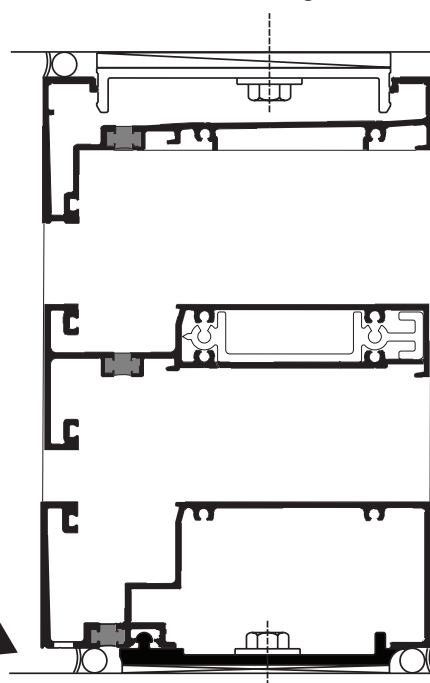

**NOTE:**  
Recess perimeter seal at Weep Hole location of Sill to prevent blockage of Weep Holes.

**DETAIL U**

**GLAZING**

1. Apply Silicone Sealant to vertical glazing pocket at vertical/horizontal intersections. Sealant must be applied to two sides of pocket only. Clearance at outside will allow water to run down to sill member. **See DETAIL V.**
2. Insert water deflector into glazing pocket and slide it down into position. Top of deflector must be flush with horizontal glazing pocket. Apply Silicone Sealant to three sides of water deflector.

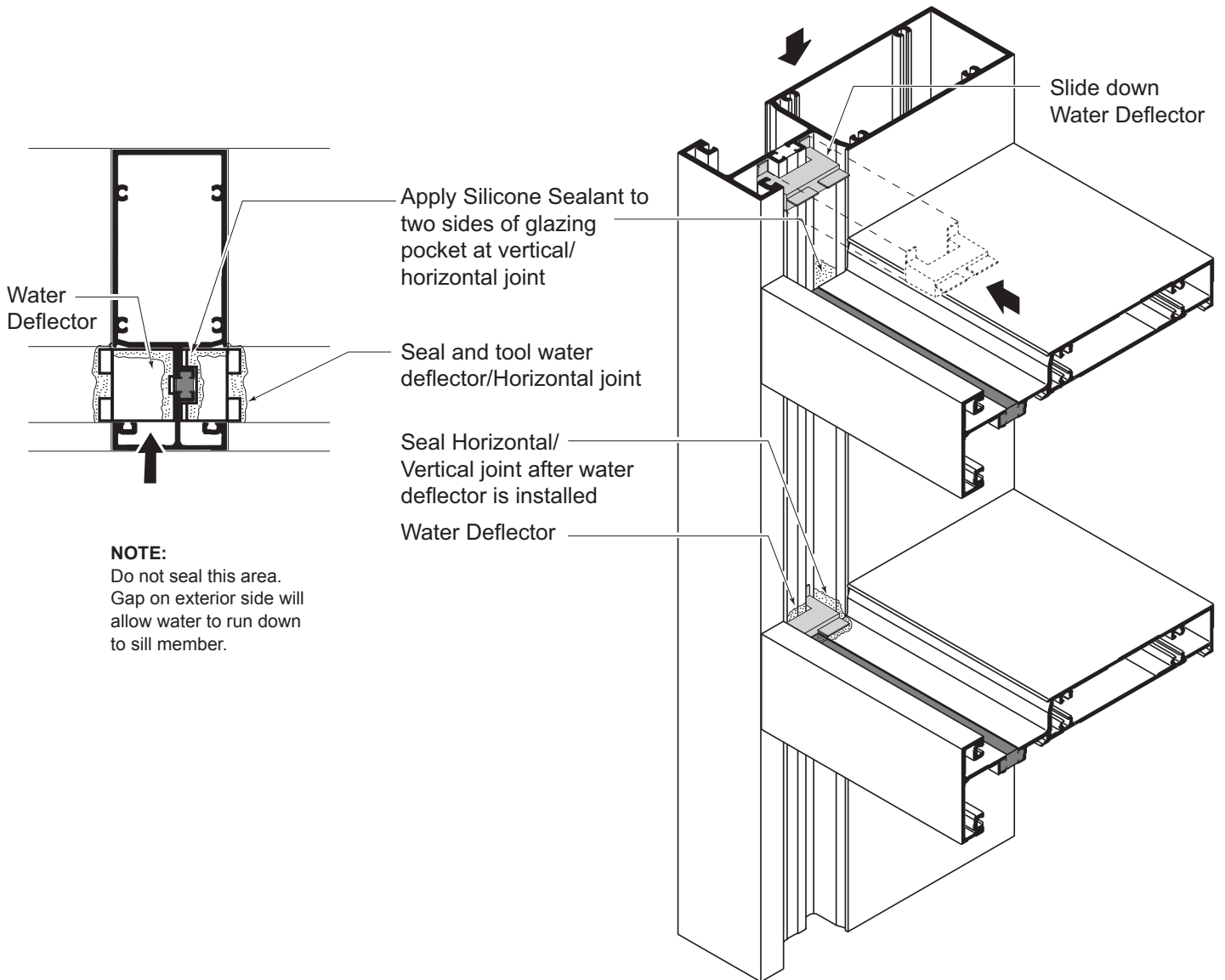

**DETAIL V**

## SERIES TN451, TT451, TN601, AND TT601 TOP NOTCH

- Place setting blocks at 1/4 or 1/8 points into intermediate horizontal members. Install weep baffles, setting chairs and setting blocks into sill member, centered at Weep Hole locations. **See DETAIL W.**

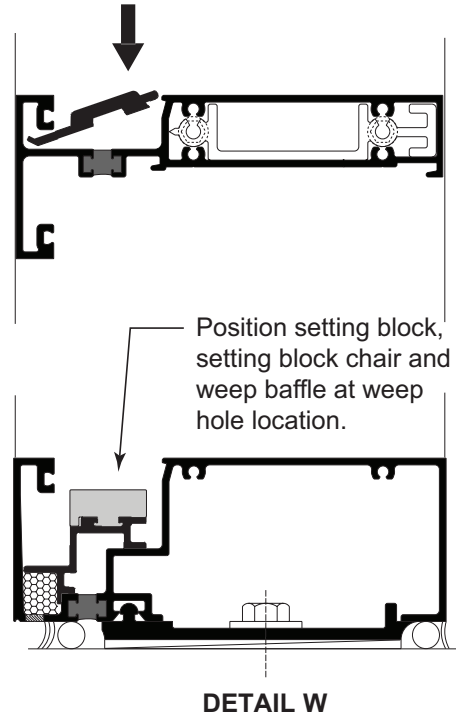

- Apply Silicone Sealant into exterior gasket reglets at corners, 2" (50.8) in each direction.
- Trim corners of exterior glazing gaskets and darts. Apply sealant to gasket corners also, 2" (50.8) in each direction, immediately before installation. **See DETAIL X.**

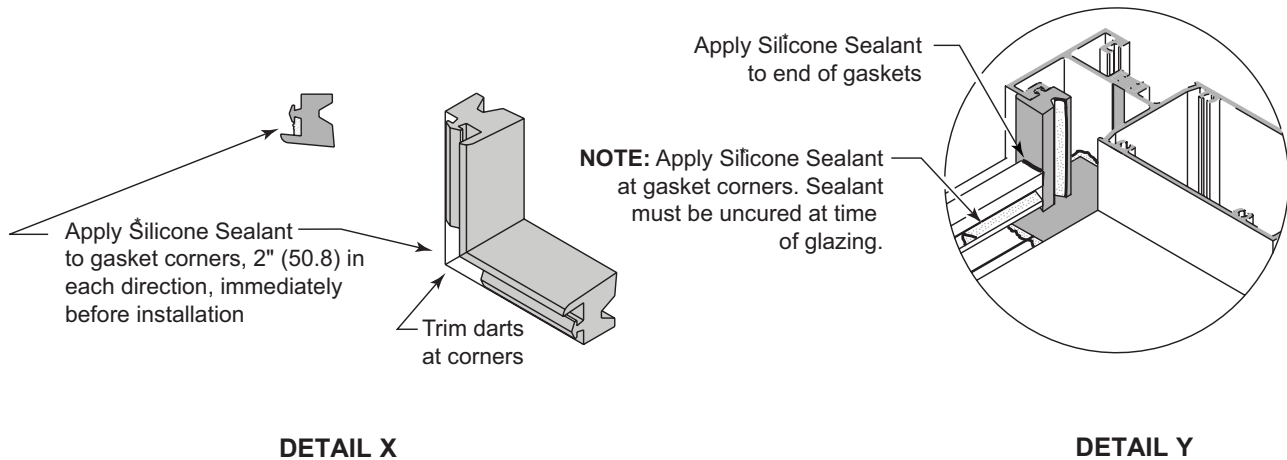

- Install exterior gaskets. Do not cut or splice gaskets. Allow 1/8" per foot additional length of gasket to allow for shrinkage, they should never be stretched to fit. Horizontal gaskets butt against verticals. **See DETAIL Y.** Start installation from corners and work toward center, making sure that corners are true and square and gasket darts are fully engaged.
- Apply bead of Silicone Sealant at gasket corners, 2" (50.8) in each direction before installing glass. **See DETAIL Y.**

[usalum.com](http://usalum.com)

V 2024-0927

Copyright © 2021 US Aluminum

All rights reserved.

™ ® Trademarks of US Aluminum and its affiliated companies or respective owners.

\*CRL items listed above or equivalent

## SERIES TN451, TT451, TN601, AND TT601 TOP NOTCH

8. To prevent glass from shifting in the opening, edge blocks should be installed, one on each side of glass at center point. Peel off adhesive and install **WB601** edge block into vertical shallow pocket. **See DETAIL Z.** Install **WB600** into vertical deep pocket after glass is set.
9. Install glass and center in opening. **See DETAIL Z** for installation sequence. Do not disturb exterior gaskets during glass installation.
10. After glass is set in place, lift slightly and press it firmly against exterior gaskets, to prevent dragging or biting on setting block. Short pieces of interior wedges may be used at setting block locations, as well as at jambs, to maintain the proper pressure.

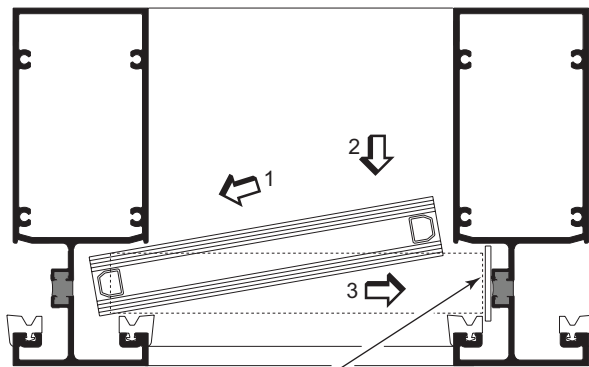

Install **WB600** edge block into vertical shallow pocket before setting glass

### GLAZING SEQUENCE

1. Into deep pocket
2. Swing to plane
3. Slide to shallow pocket
4. Down onto setting blocks

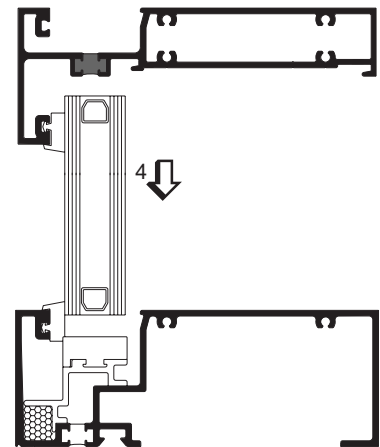

### DETAIL Z

11. Install "W" edge block into vertical deep pocket. Stretch block and slide it between glass and aluminum member into glazing pocket. Push it all the way until it clears glass and locks itself in. **See DETAIL AA.**

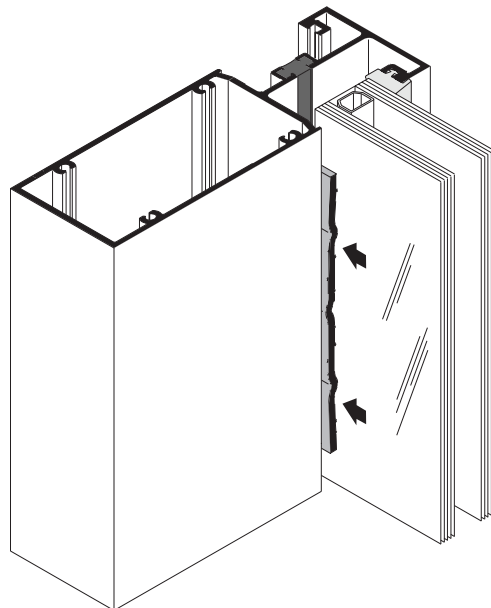

Stretch "W" block and slide it between glass and mullion into glazing pocket. Push it all the way until it clears glass and locks itself in place.



### DETAIL AA

[usalum.com](http://usalum.com)

V 2024-0927

Copyright © 2021 US Aluminum

All rights reserved.

™ ® Trademarks of US Aluminum and its affiliated companies or respective owners.

## SERIES TN451, TT451, TN601, AND TT601 TOP NOTCH

- Hook into place horizontal glass stop. See **DETAIL BB**.
- Roll in interior wedges. Butt horizontal and vertical wedges at corners, bevel as required and trim edges to correct angle. Seal corners.

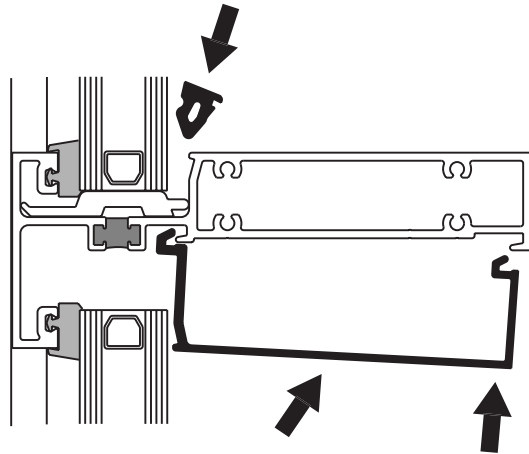

**DETAIL BB**

## OPTIONAL SYSTEM ANCHORING

When installing the system in a precast punched opening, optional anchoring is available.

- Slide anchor into end of head and sill horizontal. Refer to shop drawings for quantity and location. See **DETAIL CC**.
- Set system into opening and secure with fasteners determined by shop drawings.

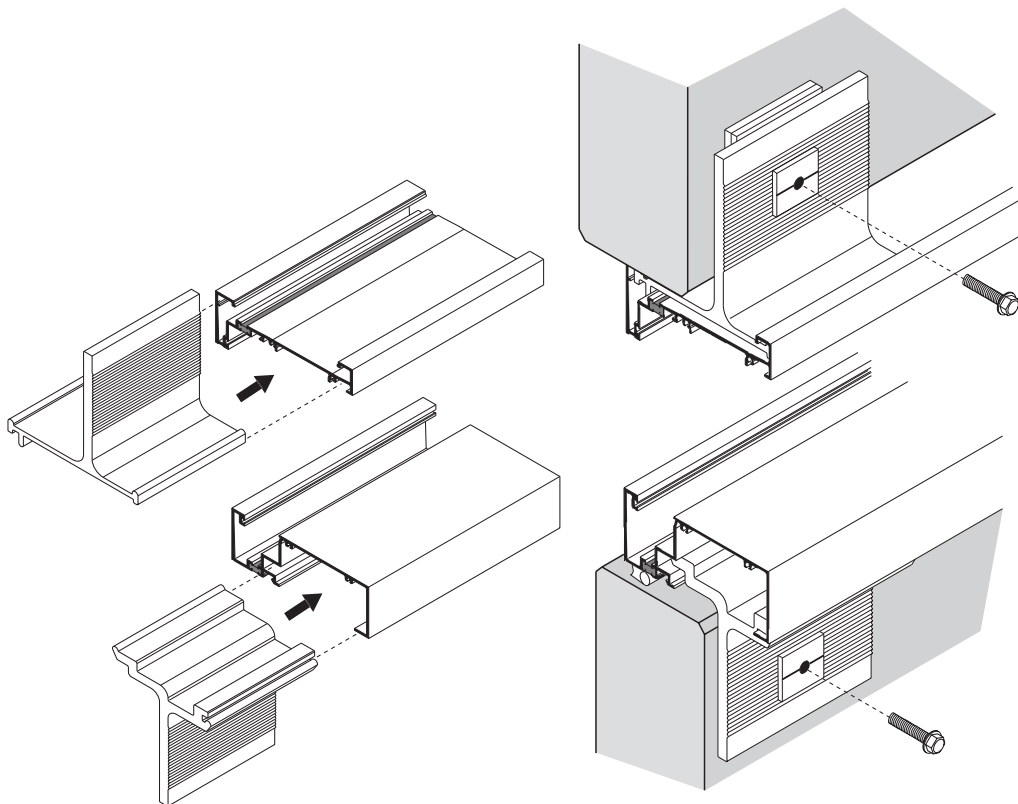

**DETAIL CC**

[usalum.com](http://usalum.com)

V 2024-0927

Copyright © 2021 US Aluminum

All rights reserved.

™ ® Trademarks of US Aluminum and its affiliated companies or respective owners.

# GUIDE TO SEALANTS

NOTE: All sealants must be tooled to ensure proper adhesion.

## WATERPROOFING

### • Typical Weather Sealant

Sill to Subsill, End Dams, Screw Heads, and Threshold to Door Frame Sealing.

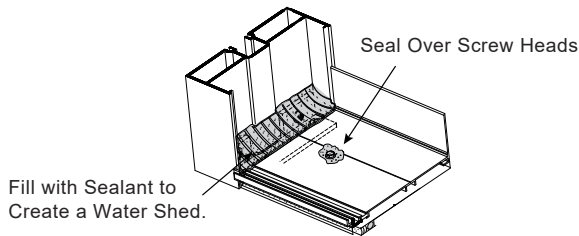

## EXPANSION

### • Typical Weather Sealant

Expansion Joints.

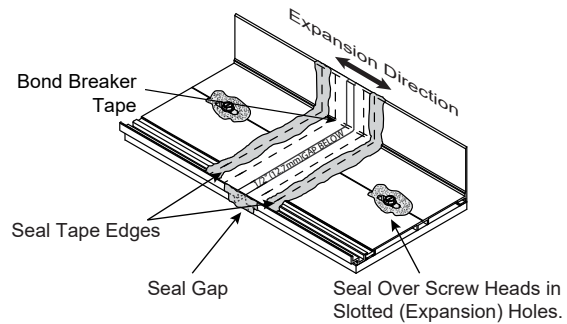

## JOINT ADHESIVE

### • Typical Weather Sealant

Small Joints, End Joints and Buttered Surfaces, Water Diverters, End Dams, and Reglet Fills.

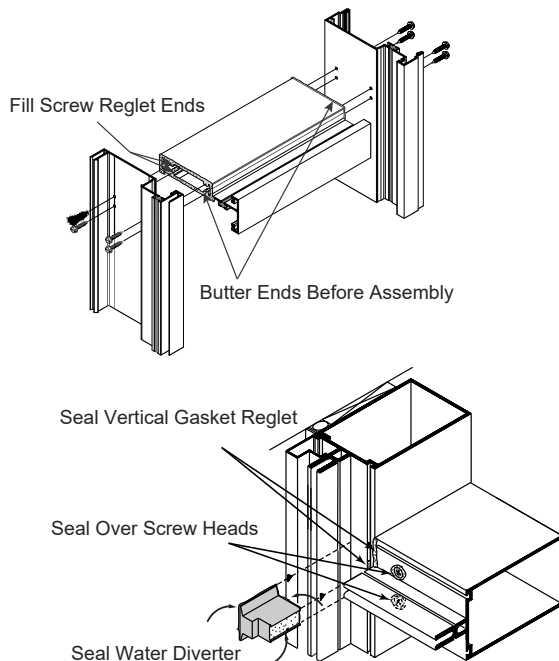

## PERIMETER

### • Typical Weather Sealant

Perimeter Seals, Expansion Joints, Sill and Threshold Beds, Concrete, Wood, and Steel Openings.

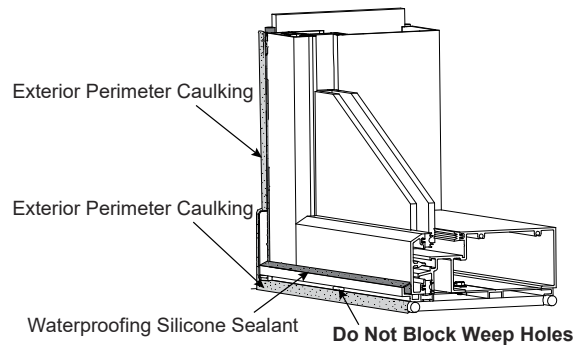

## STRUCTURAL

### • ALL STRUCTURAL SEALANTS REQUIRE TESTING AND APPROVAL.

Glass-to-Glass or Glass-to-Metal