

INSTALLATION INSTRUCTIONS

SERIES DHS-500

IMPACT RESISTANT STOREFRONT

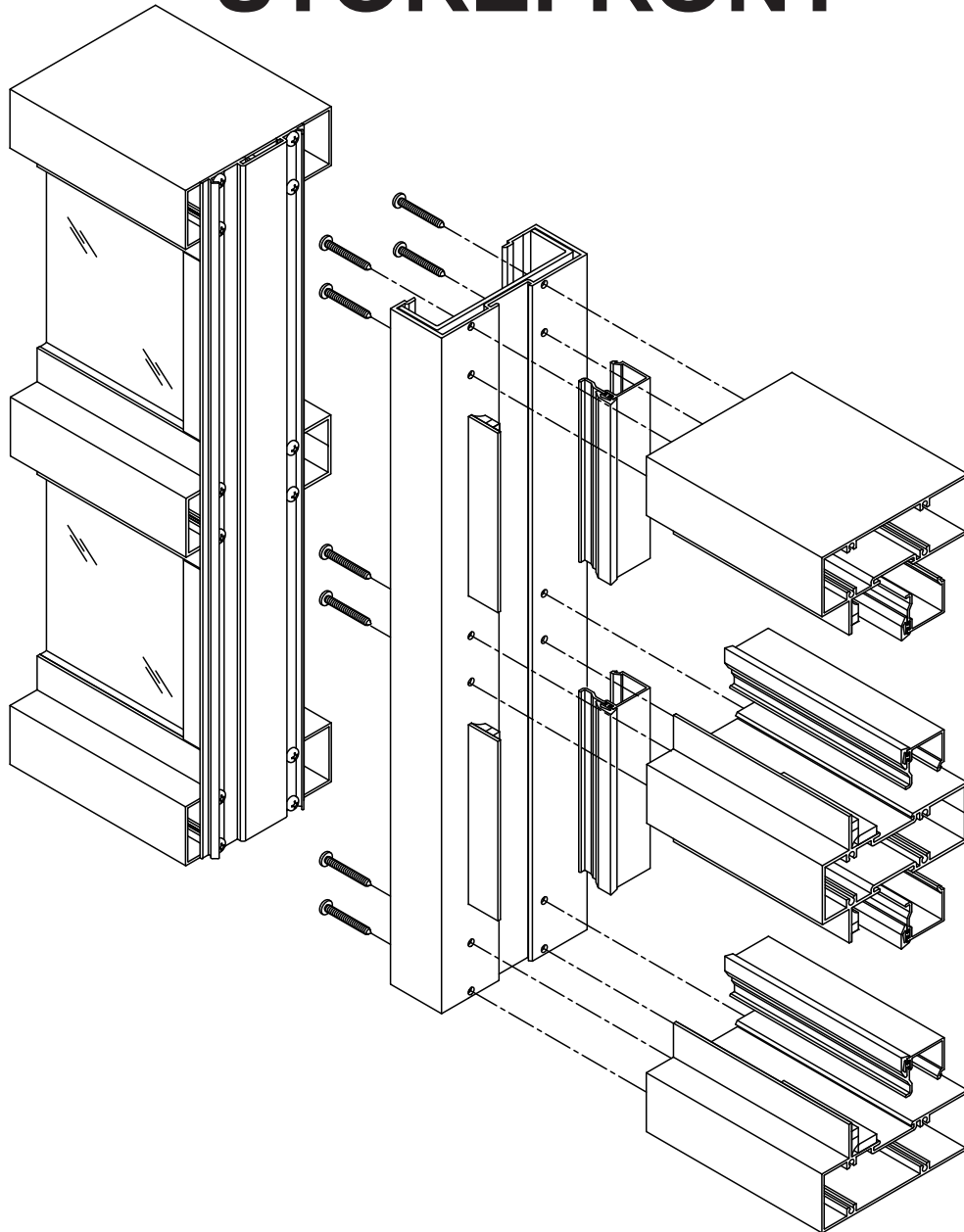

Phone: (800) 421-6144 • Fax: (800) 582-7501
crlaurence.com • usalum.com • crl-arch.com

11M0122

HANDLING, STORAGE, AND PROTECTION OF ALUMINUM

The following precautions are recommended to protect the material against damage. Following these precautions will help ensure early acceptance of your products and workmanship.

A. HANDLE CAREFULLY.

All aluminum materials at job site must be stored in a safe place, well removed from possible damage by other trades. Cardboard wrapped or paper interleaved materials must be kept dry.

B. CHECK ARRIVING MATERIALS.

Check for quantities and keep records of where various materials are stored.

C. KEEP MATERIALS AWAY FROM WATER, MUD, AND SPRAY.

Prevent cement plaster or other materials from damaging the finish.

D. PROTECT THE MATERIALS AFTER ERECTION.

Protect erected frame with polyethylene or canvas splatter screen. Cement, plaster, terrazzo, other alkaline solutions, and acid based materials used to clean masonry are harmful to the finish. If any of these materials come in contact with the aluminum, immediately remove with water and mild soap.

IMPORTANT: READ THIS MANUAL THOROUGHLY BEFORE BEGINNING INSTALLATION.

ORDER OF ASSEMBLY AND INSTALLATION

INTRODUCTION	4
SPECIFICATIONS	4
PARTS LIST	5
DETERMINE FRAME SIZE	6
FABRICATION	7 - 10
Vertical Mullions	7
Vertical Pocket Fillers	8
Steel Reinforcing	9
Head, Horizontal and Sill Mullions, and Glass Stops	10
Jamb Mullions	10
FRAME ASSEMBLY	11
GLAZING	12 - 14
Prepare frame	12
Install glass	13
Ensure good adhesion and seal	13
Install temporary glass stops	14
FRAME INSTALLATION	15 - 17
Prepare frame	15
Order of Installation	15
Installation with door	16
Installation without door	16
Anchor frame	17
Seal perimeter	17
Install full length glass stops	17
SEAL EXTERIOR	18
JOB SITE ESSENTIALS	19

NOTE: Dimensions in parentheses () are millimeters unless otherwise noted.

GENERAL INSTALLATION NOTES

Recommended Guidelines For All Installations:

- 1. REVIEW CONTRACT DOCUMENTS.** Check shop drawings, installation instructions, architectural drawings, and shipping lists to become thoroughly familiar with the project. The shop drawings take precedence and include specific details for the project. Note any *field verified* notes on the shop drawings prior to installing. The installation instructions are of a general nature and cover most conditions.
- 2. INSTALLATION.** All materials are to be installed plumb, level, and true. Install operable windows preglazed only.
- 3. BENCH MARKS.** All work should start from bench marks and/or column lines as established by the architectural drawings and the general contractor with guaranteed accuracy. Working from these datum points and lines determine:
 - a) The plane of the wall in reference to offset lines provided on each floor.
 - b) The finish floor lines in reference to bench marks on the outer building columns.
 - c) Mullion spacing from both ends of masonry opening to prevent dimensional build-up of daylight opening.
- 4. FIELD WELDING.** All field welding must be adequately shielded to avoid any splatter on glass or aluminum. Results will be unsightly and/or structurally unsound. Advise general contractor and other trades accordingly. All field welds of steel anchors must receive touch-up paint (zinc chromate) to avoid rust.
- 5. SURROUNDING CONDITIONS.** Make certain that construction which will receive your materials is in accordance with the contract documents. If not, notify the general contractor in writing and resolve differences before proceeding with work.
- 6. ISOLATION OF ALUMINUM.** Aluminum to be placed in direct contact with uncured masonry or incompatible materials should be isolated with a heavy coat of zinc chromate or bituminous paint.
- 7. SEALANTS.** Sealants must be compatible with all materials with which they have contact, including other sealant surfaces. Consult with sealant manufacturer for recommendations relative to joint size, shelf life, compatibility, cleaning, priming, tooling, adhesion, etc. It is the responsibility of the **Glazing Contractor** to submit a statement from the sealant manufacturer indicating that glass and glazing materials have been tested for compatibility and adhesion with glazing sealants, and interpreting test results relative to material performance, including recommendations for primers and substrate preparation required to obtain adhesion. The chemical compatibility of all glazing materials and framing sealants with each other and with like materials used in glass fabrication must be established. This is required on every project.
- 8. FASTENING.** Within the body of these instructions "fastening" means any method of securing one part to another or to adjacent materials. Only those fasteners used within the system are specified in these instructions. Due to the varying perimeter conditions and performance requirements, perimeter and anchor fasteners are not specified in these instructions. For perimeter and anchor fasteners refer to the shop drawings or consult the fastener supplier.
- 9. BUILDING CODES.** Due to the diversity in state/provincial local, and federal laws and codes that govern the design and application of architectural products, it is the responsibility of the individual architect, owner, and installer to assure that products selected for use on projects comply with all the applicable building codes and laws. U.S. Aluminum exercises no control over the use or application of its products, glazing materials, and operating hardware and assumes no responsibility thereof.
- 10. EXPANSION JOINTS.** Expansion joints and perimeter seals shown in these instructions and in the shop drawings are shown at normal size. Actual dimensions may vary due to perimeter conditions and/or difference in metal temperature between the time of fabrication and the time of installation. Gaps between expansion members should be based on temperature at time of installation.
- 11. WATER HOSE TEST.** As soon as a representative amount of the wall has been glazed (500 square feet or 46.5 m²) a water hose test should be conducted in accordance with AAMA 501.2 specifications to check the installation. On all jobs the hose test should be repeated every 500 square feet (46.5 m²) during the glazing operation.
- 12. COORDINATION WITH OTHER TRADES.** Coordinate with the general contractor any sequence with other trades which offset curtain wall installation (i.e. fire proofing, back-up walls, partitions, ceilings, mechanical ducts, converters, etc.)
- 13. CARE AND MAINTENANCE.** Final cleaning of exposed aluminum surfaces should be done in accordance with AAMA 609.1 for anodized aluminum and 610.1 for painted aluminum.

INTRODUCTION

The DHS-500 is a 5" (127) deep Hurricane Resistant Storefront System designed for all commercial applications including retail space, hotels, condominiums, office buildings, institutional facilities, and industrial structures. The DHS-500 is engineered to deliver superior quality, strength, and durability, while maintaining a truly elegant appearance.

SPECIFICATIONS

PERFORMANCE

Meets all Miami-Dade County, Florida, air, water, structural and impact requirements:

- Large and Small missile impact test
- Maximum design pressure of +130 psf / -130 psf
- Water resistant at 15 psf
- Air Infiltration = 0.050 cfm/sq. ft. at a pressure differential of 6.24 psf

STANDARD FEATURES

- Maximum panel size: 48" x 120" (1219 x 3048)
- Horizontal and vertical aluminum members frame 1.75" x 5" (44.5 x 127)
- Frame assembled with four (4) #12 x 1.25" (38.1) PHSMS #10 head at each corner

PRODUCT APPLICATIONS

The DHS-500 is an impact window wall system for use in all commercial applications, condominiums, lofts, hotels and apartments, and is intended to be installed in punched openings or as a liner frame with other Delta Doors impact door series.

MATERIALS

- Aluminum frame sections should be extruded aluminum AA 6063 T6 alloy
- Glazing materials shall be:

Cat.No.V220414 Structural Glazing Tape

Cat.No.995B Dow Silicone Structural Adhesive

3/16" x 3/8" (4.8 x 9.5) Neoprene Glazing Gasket

Option "A"

Glass: 9/16" (14.3) laminated impact glass 0.075" (1.9)

VS02 Vanceva composite interlayer by Solutia

Laminated Glass Composition:

1/4" (6.4) heat-strengthened laminated glass • 0.075" (1.9) VS02 interlayer • 1/4" (6.4) heat-strengthened glass

Option "B"

Glass: 9/16" (14.3) laminated impact glass

.090" (2.3) PVB interlayer by Solutia or DuPont







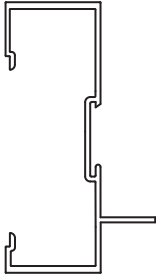

Laminated Glass Composition:

Exterior Lite: 1/4" (6.4) heat-strengthened glass • .090" (2.3) PVB interlayer

Interior Lite: 1/4" (6.4) heat-strengthened glass

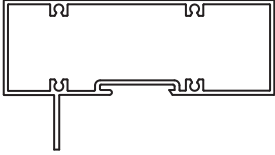
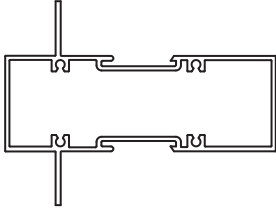
Tint of glass available as selected by the architect/owner

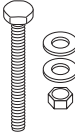
PARTS LIST

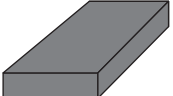
<p>DLD-100</p>  <p>Jamb / Vertical</p>	<p>1-5/16" x 4-5/8" (23.8 x 117.5) 1/8" (3.2) Minimum Thickness Steel Reinforcer</p>  <p>Used in All Verticals Except Jamb</p>	<p>DLD-101</p>  <p>Pocket Filler</p>
<p>DLD-102</p>  <p>Glass Stop</p>	<p>DLD-103</p>  <p>Head / Sill</p>	<p>DLD-104</p>  <p>Horizontal Mullion</p>
<p>#12 x 1-3/4" PHSMS Type AB</p>  <p>Fastener - Frame Assembly</p>	<p>12NWFS22 1/4"-20 x 2" HHMS With Locknut and (2) Washers</p>  <p>Fastener - Frame Installation</p>	<p>10 X 1" Self-Drilling Flat Phillips 410 Stainless</p>  <p>Fastener - Frame Assembly</p>
<p>BCE-475</p>  <p>Flat Filler</p>	<p>SB574</p>  <p>Glass Setting Block</p>	

DETERMINE FRAME SIZE

1. Check the rough opening for correct size, squareness, and plumb as determined by tolerances listed in the architectural specifications and the shop drawings.
2. Measure the rough opening at the top, middle, and bottom. Select the smallest dimension measure and subtract 1/2" (12.7) to determine the frame width.
3. Measure the height of the rough opening at several points along the opening. Select the smallest dimension and subtract 1/2" (12.7) to determine the frame height.

NOTE: If project requires wood buck installation, determine measurements from wood buck.

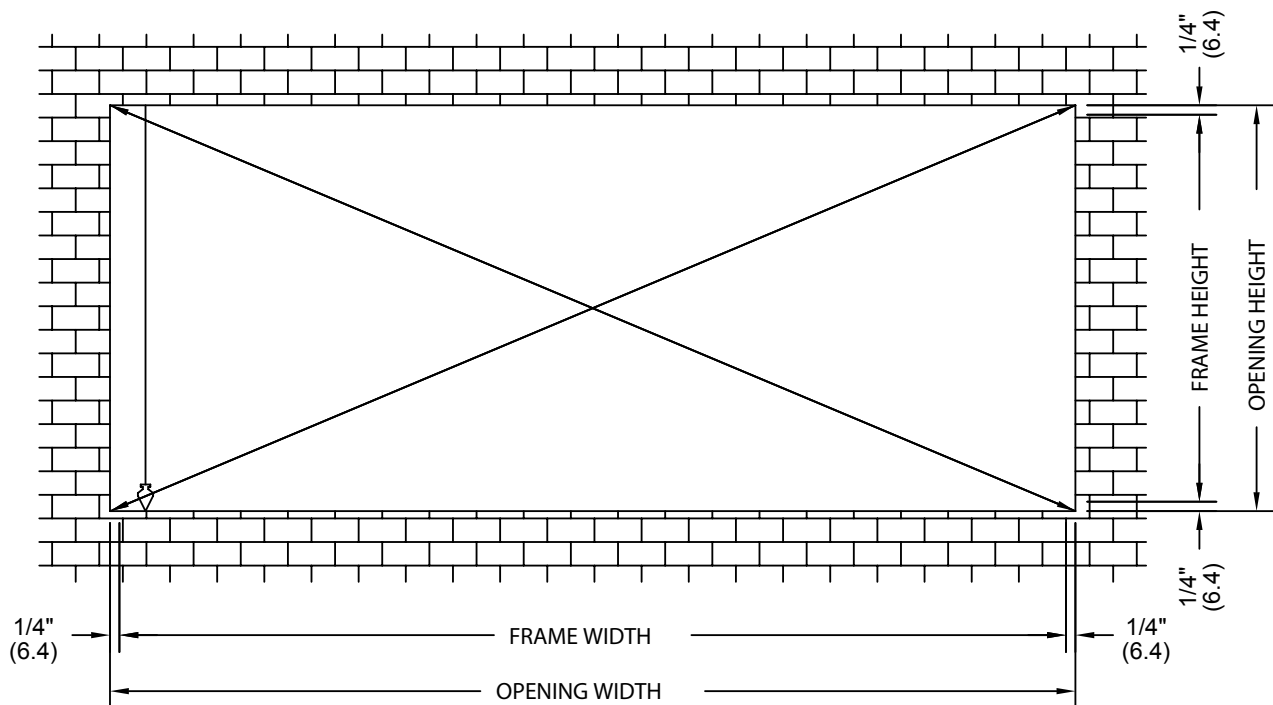

FABRICATION

Vertical Mullions

NOTE: Refer to CRL shop drawings to confirm anchor size and spacing.

Cut DLD-100 to length, frame height determined.

Notch to accept horizontals.

Drill holes shown:

.236" (6.0) diameter holes attach horizontals

.323" (8.2) diameter holes anchor assembled frames together

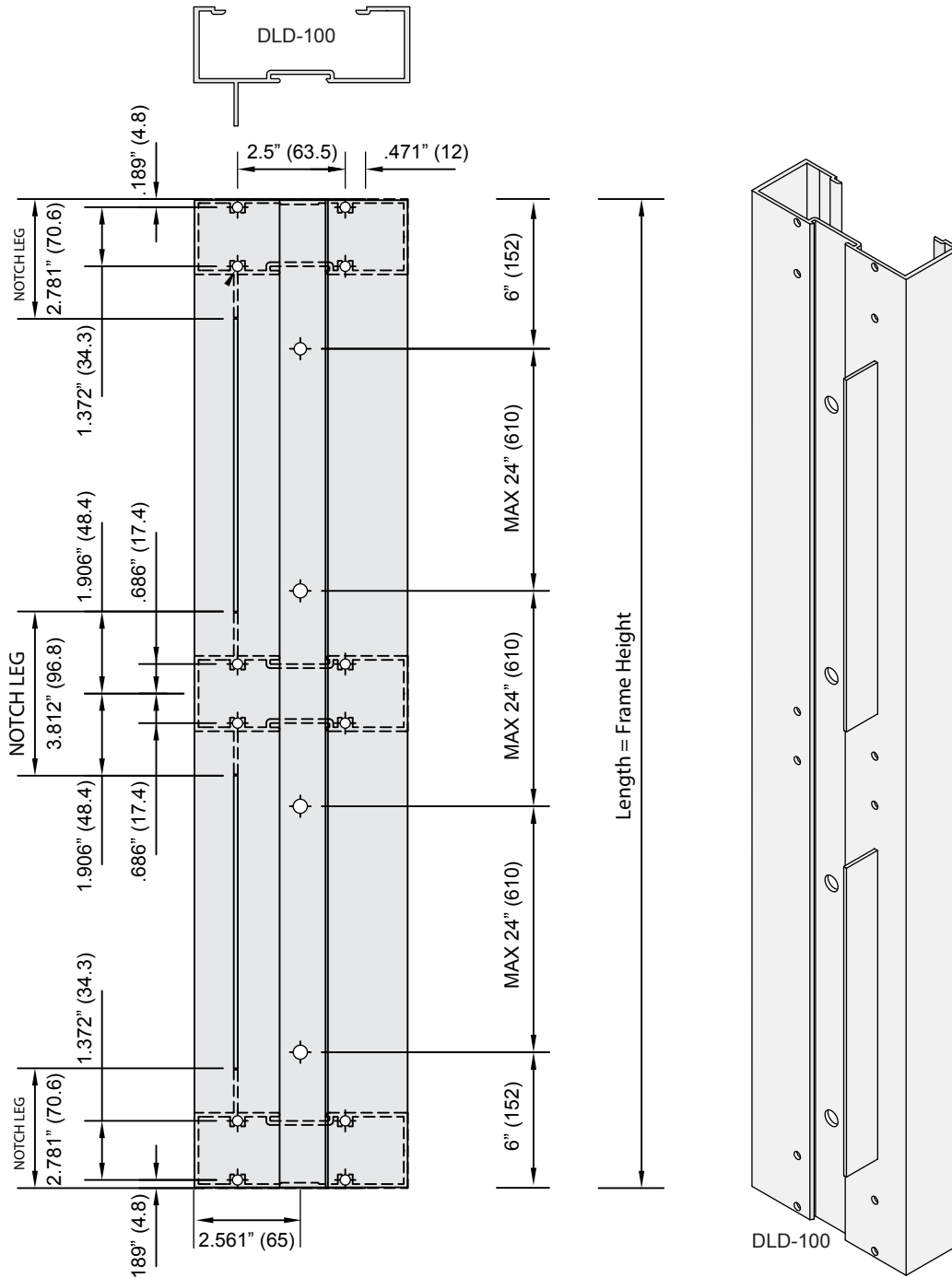

FABRICATION (CONTINUED)

Vertical Pocket Fillers

NOTE: Refer to CRL shop drawings to confirm anchor size and spacing.

Cut DLD-101 to length, frame height determined.

Notch to accept horizontals.

Drill holes shown:

.236" (6.0) diameter holes attach horizontals

.323" (8.2) diameter holes anchor assembled frames together

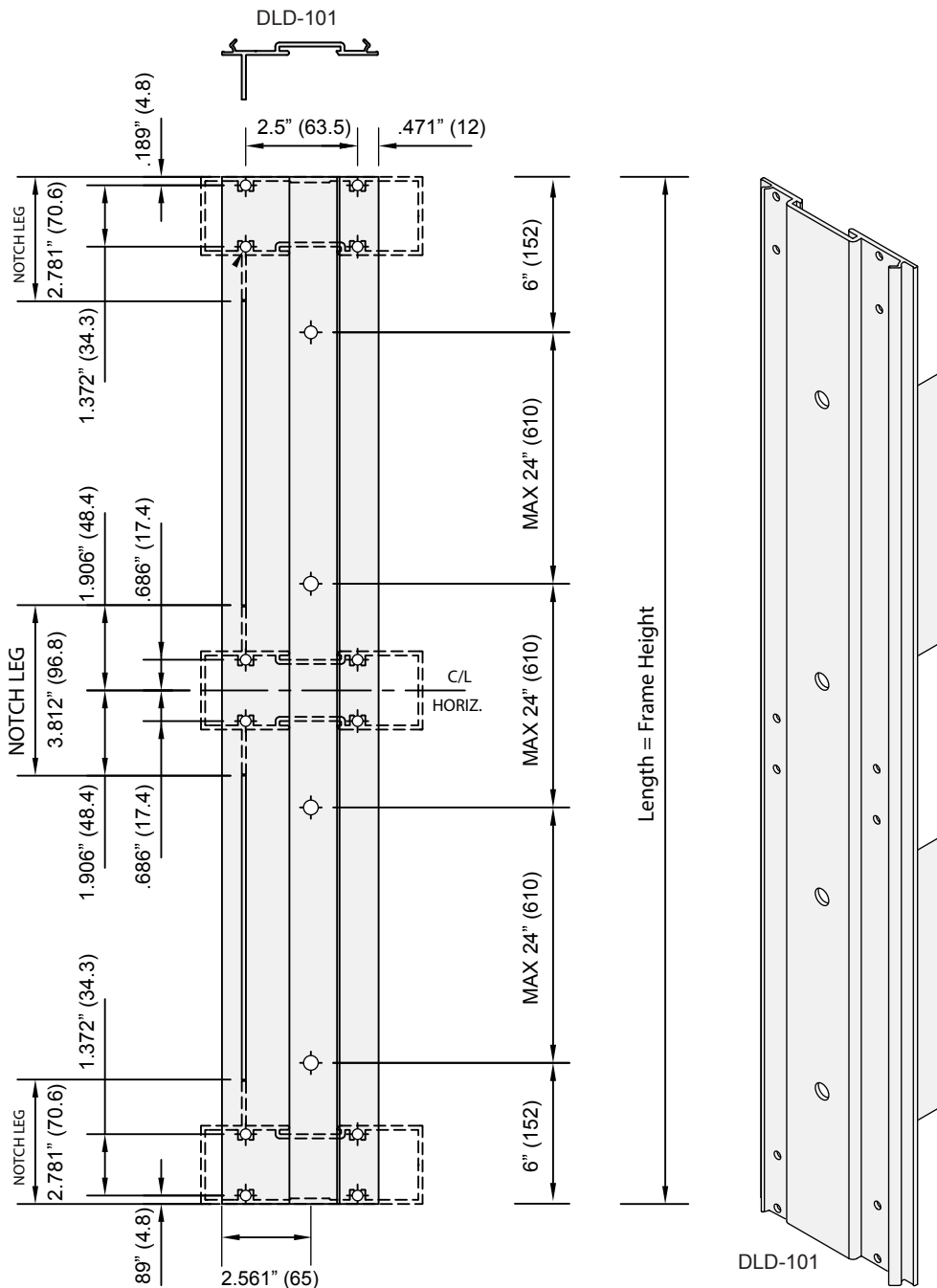

FABRICATION (CONTINUED)

Steel Reinforcing

NOTE: Steel reinforcing is used with all DLD-100 verticals except jambs. The reinforcing is installed and anchor holes are drilled during assembly.

Cut steel reinforcing to length minus 1" (25.4).

Drill holes shown:

.125" (3.2) diameter holes attach steel to DLD-100

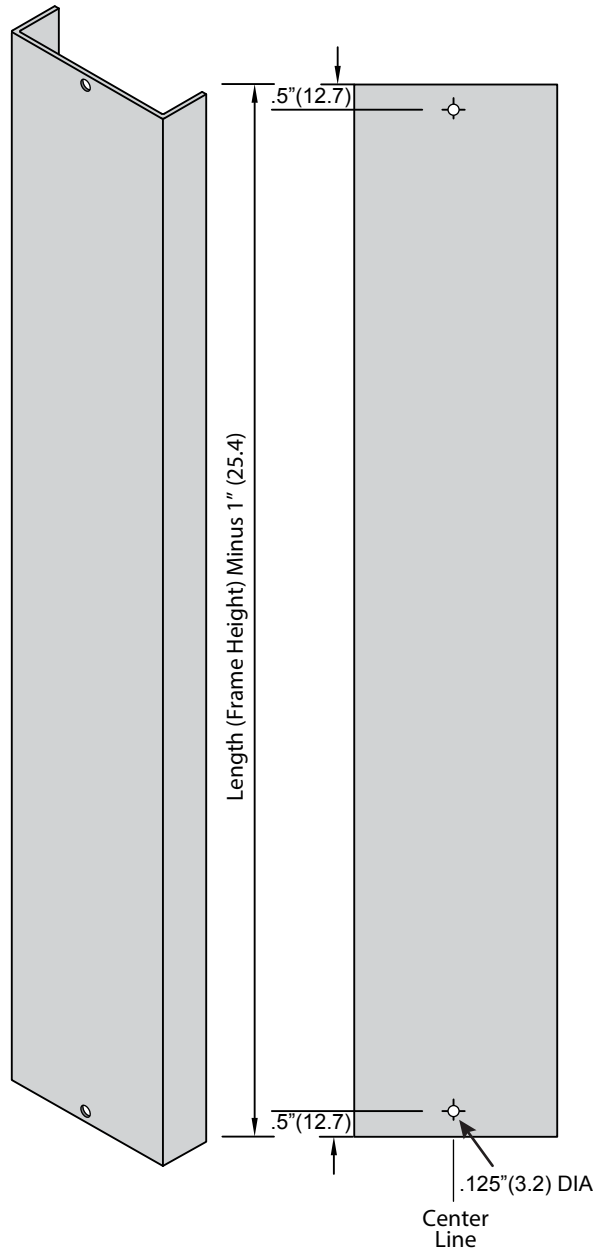

FABRICATION (CONTINUED)

Head, Horizontal and Sill Mullions, and Glass Stops

NOTE: Refer to CRL shop drawings to confirm anchor size and spacing.

Cut DLD-103 and DLD-104 to length, daylight opening between verticals.

Drill anchor holes in DLD-103 head and sill according to CRL shop drawings.

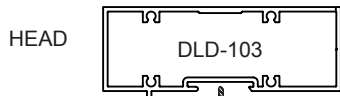

* Drill Anchor Holes

HORIZONTAL MULLION

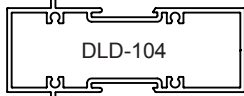

* Drill Anchor Holes

SILL



* Refer to CRL shop drawings for anchor hole placement.

DLD-102 glass stops horizontals run through. Cut verticals to daylight opening minus 1-7/8" (47.6)

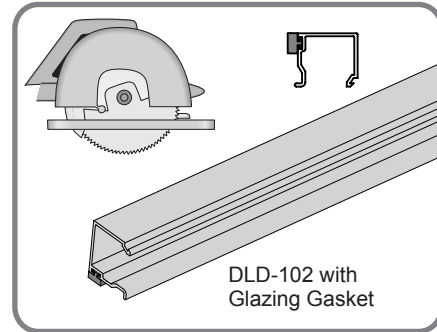

DLD-102 with Glazing Gasket

DLD-102 vertical = length minus 1-7/8" (47.6)

DLD-102 vertical = length minus 1-7/8" (47.6)

DLD-102 horizontal = length

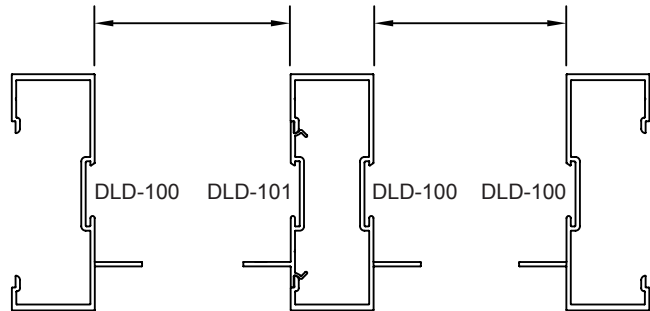

Jamb Mullions

NOTE: Refer to CRL shop drawings to confirm anchor size and spacing.

Fabricate DLD-100 as shown on page 7. Install BCE-475 flat filler at all anchor locations and stake to hold in place.

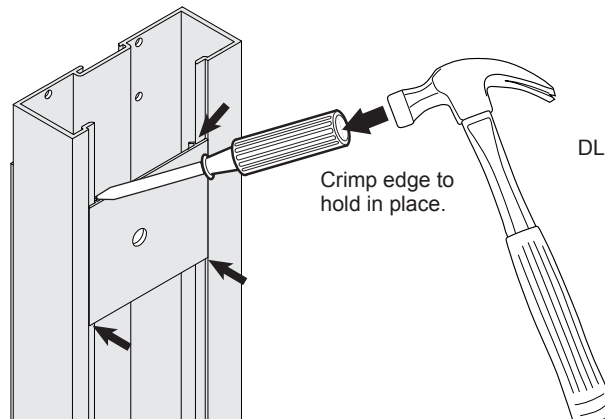
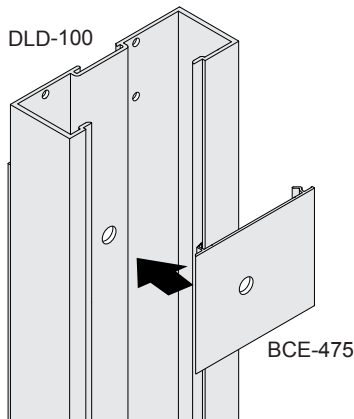

Crimp edge to hold in place.

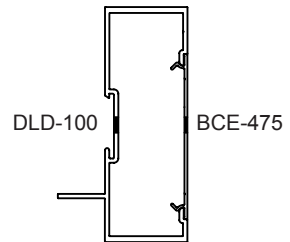

FRAME ASSEMBLY

DHS-500 frames are assembled as individual bays that are later snapped together after they are glazed.

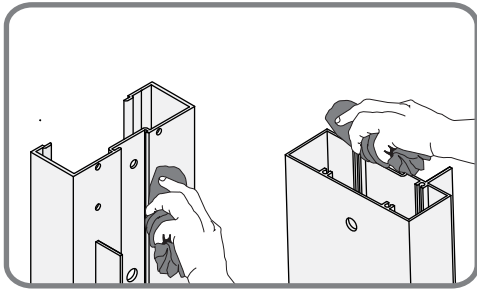

Clean silicone contact surface with isopropyl (50%) alcohol.

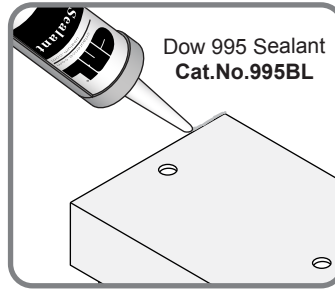

Dow 995 Sealant
Cat.No.995BL

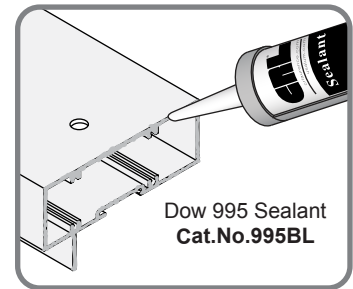

Dow 995 Sealant
Cat.No.995BL

Run bead of **Cat.No.995BL** silicone along edges to be joined.

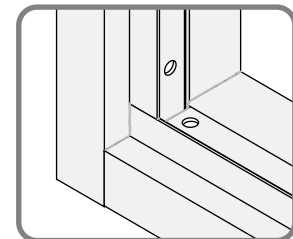
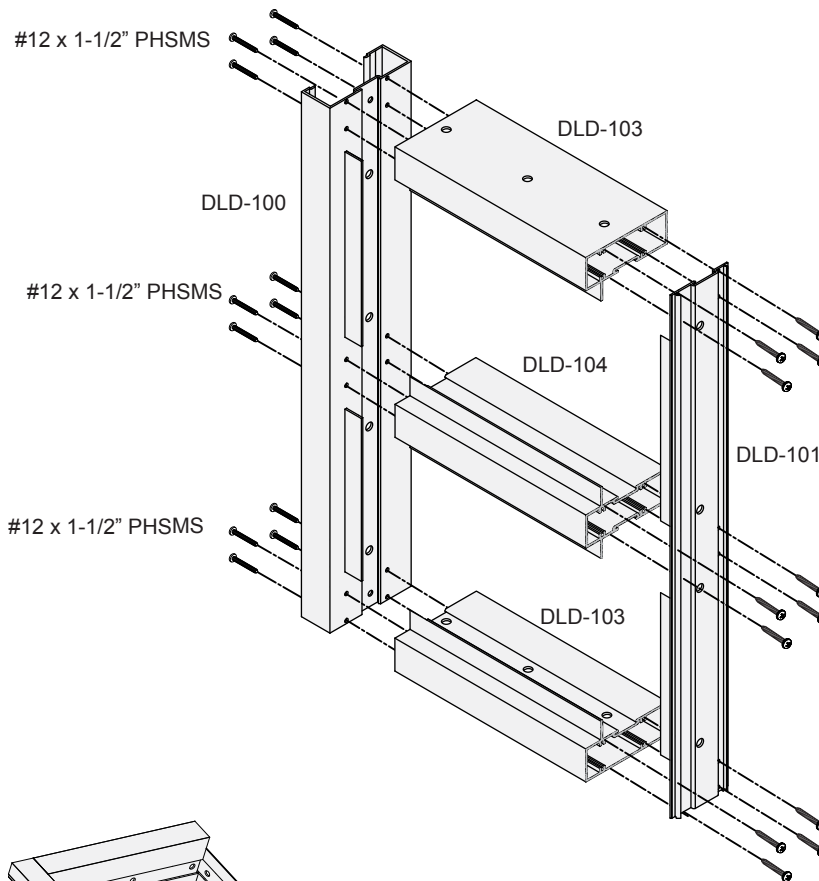

Remove excess sealant.

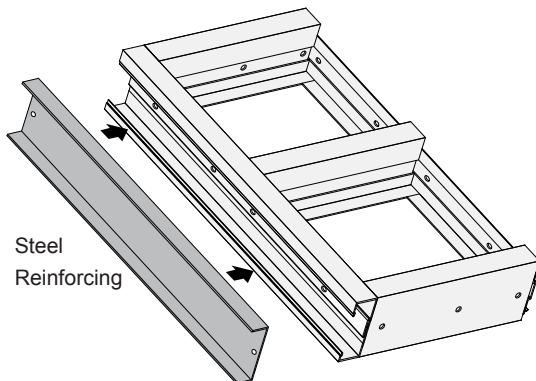

Steel Reinforcing

Insert steel reinforcing in DLD-100.

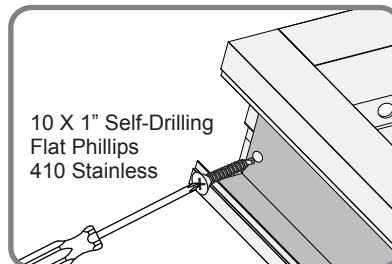

10 X 1" Self-Drilling
Flat Phillips
410 Stainless

Secure at top and bottom.

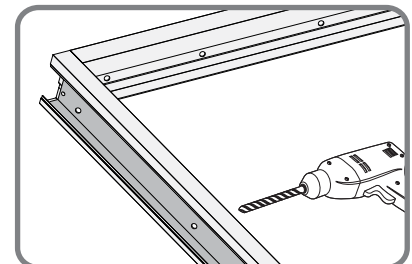

Drill through anchor holes.

GLAZING

DHS-500 frames must be bench glazed with frames lying down horizontally prior to being snapped together. Calculate glass sizes: Glass Size equals Daylight Opening minus 3/8" (9.5) (for vertical and horizontal).

1. Prepare frame

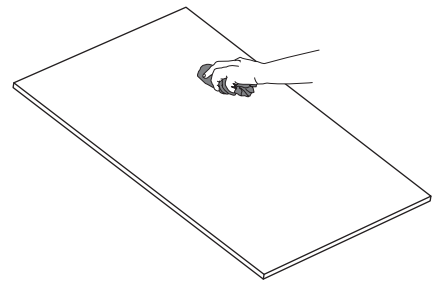
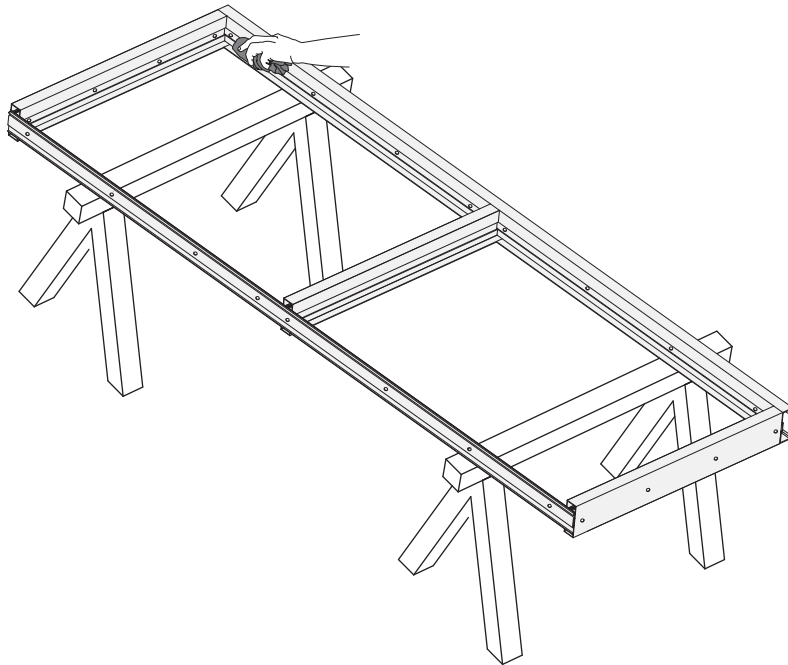

Clean glass with isopropyl (50%) alcohol.

Clean frame glazing leg with isopropyl (50%) alcohol.

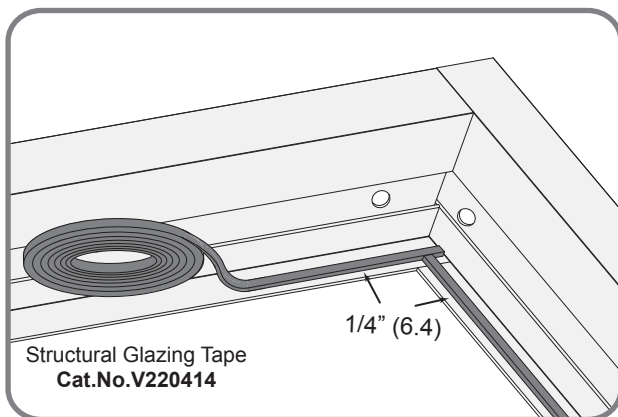

Install glazing tape 1/4" (6.4) from glazing leg edge. Horizontals run through. Do not stretch tape.

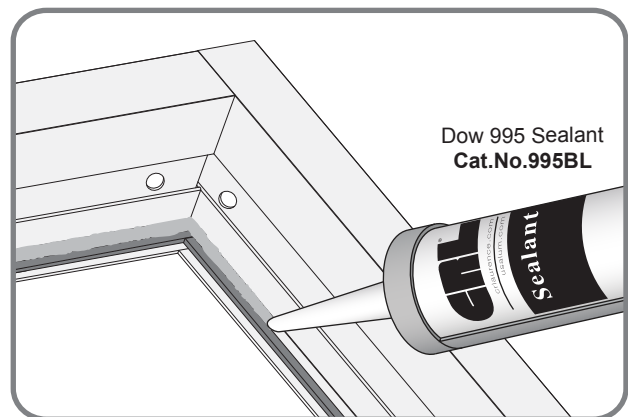

Run continuous bead **Cat.No.995BL** structural sealant 1/2" (12.7) wide on the glazing leg, filling the area behind glazing tape.

NOTE:: When installing 1-5/16" (33.3) IG Unit, use V210614 3/16" x 1/4" (4.8 x 6.4) glazing tape, TR17005E setting blocks with DLD 132 glass stops.

GLAZING (CONTINUED)

2. Install glass

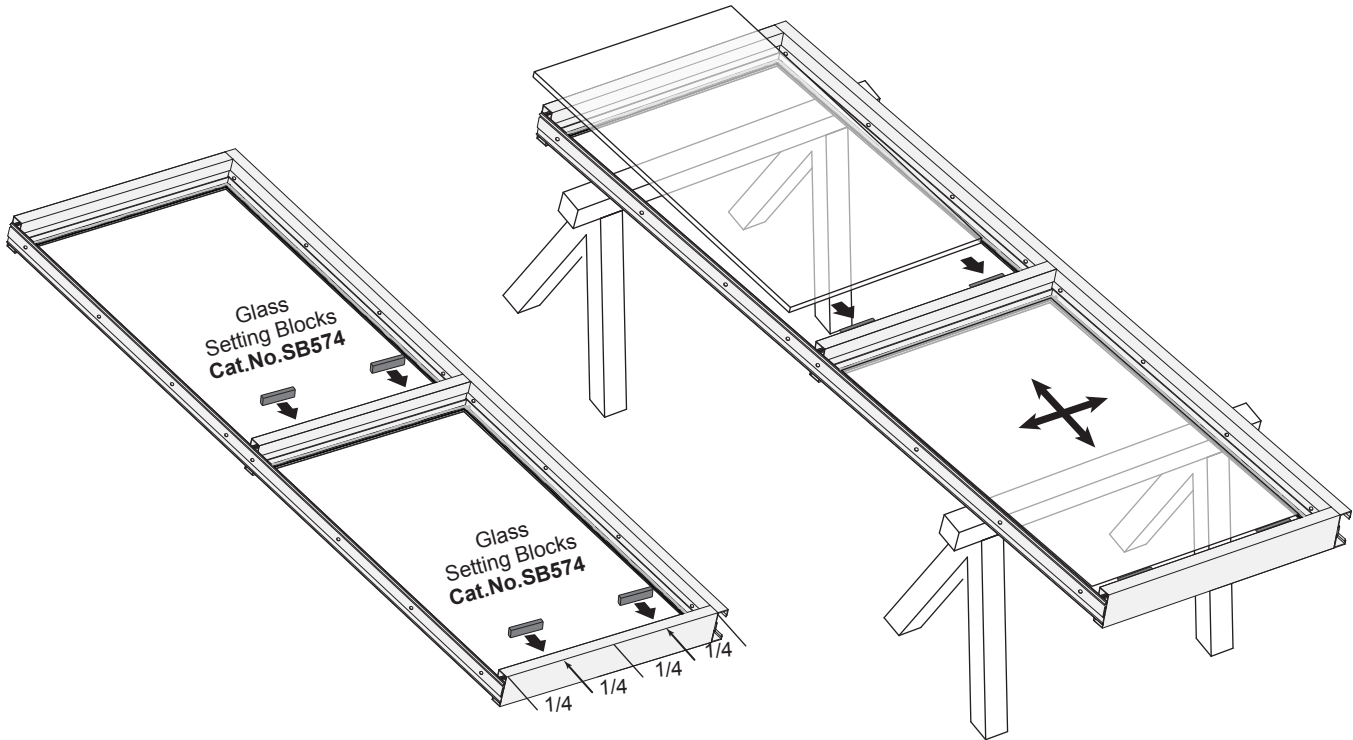

Install setting blocks at quarter points on bottom unless CRL shop drawings indicate otherwise.

Carefully place glass against setting blocks. Center to opening and slowly lower onto frame.

3. Ensure good adhesion and seal

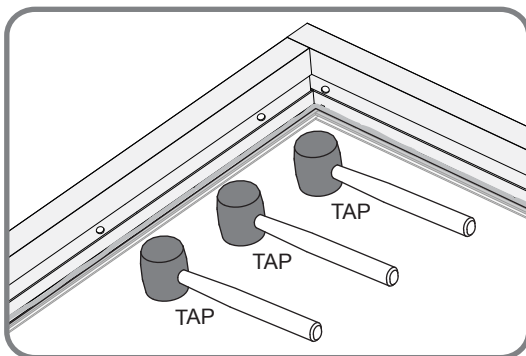

Tap around glass edges to release trapped air pockets.

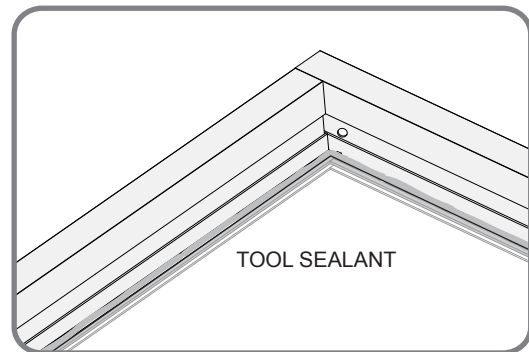

Tool sealant to ensure good seal.

GLAZING (CONTINUED)

4. Install temporary glass stops

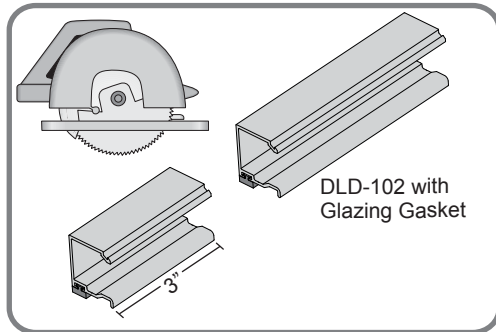

Cut 3" (76.2) temporary glass stops.

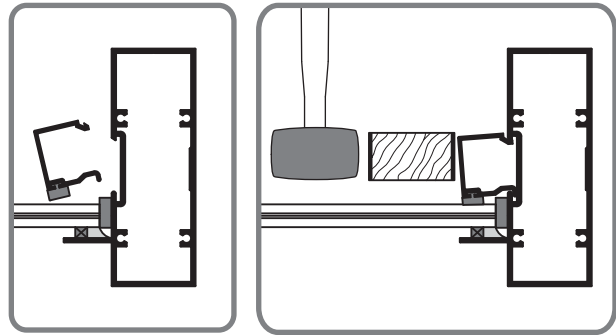

Insert temporary stop at an angle and tap into place with mallet and wood block.

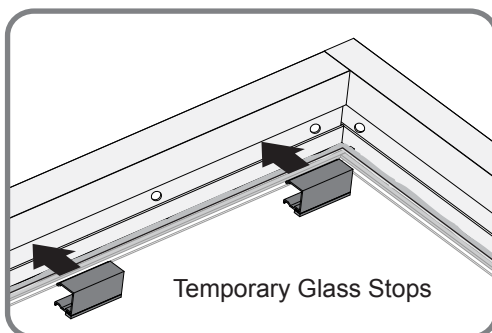
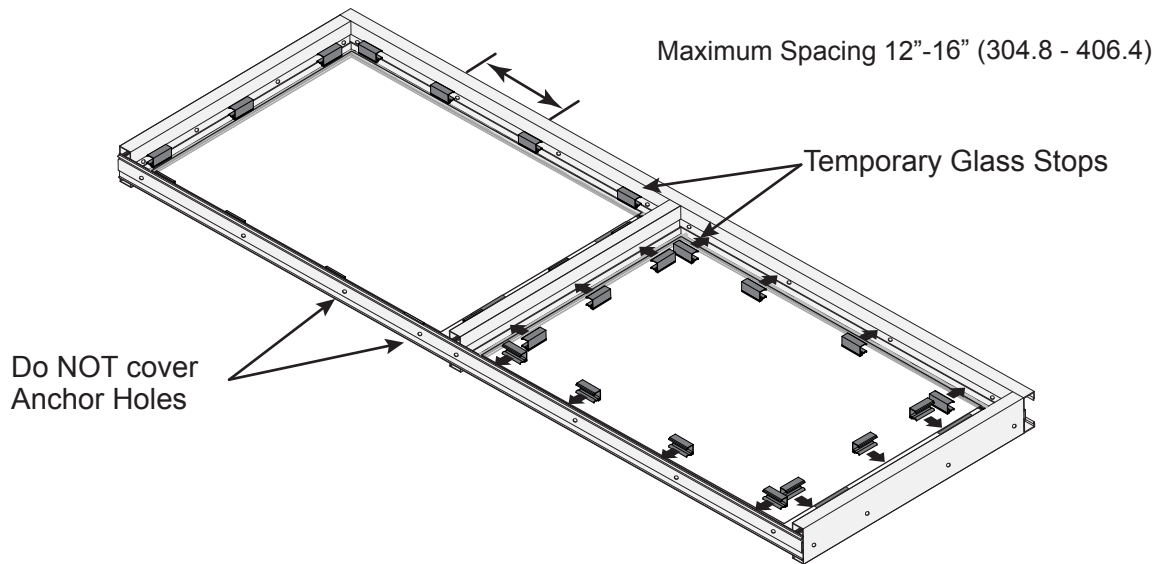

① Install on horizontals.

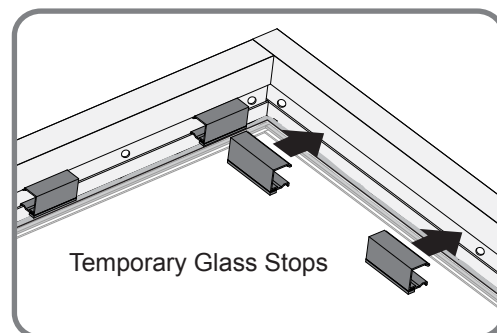

② Then install on verticals.

NOTE: Allow silicone to cure as recommended by sealant manufacturer before snapping frames together or standing frames up vertically.

FRAME INSTALLATION

1. Prepare frame

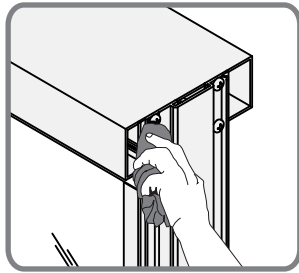

Clean silicone contact surface with isopropyl (50%) alcohol.

DLD-100

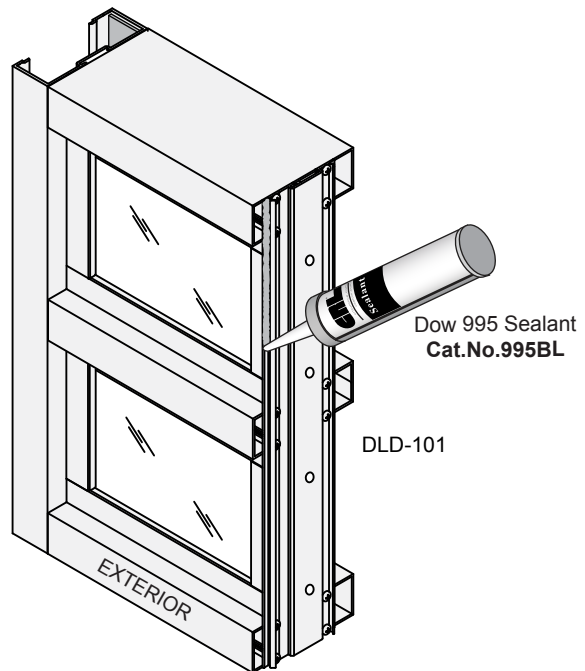

Dow 995 Sealant
Cat.No.995BL

DLD-101

Run bead of **Cat.No. 995BL** silicone on edge of DLD-101 on exterior side.

Order of Installation

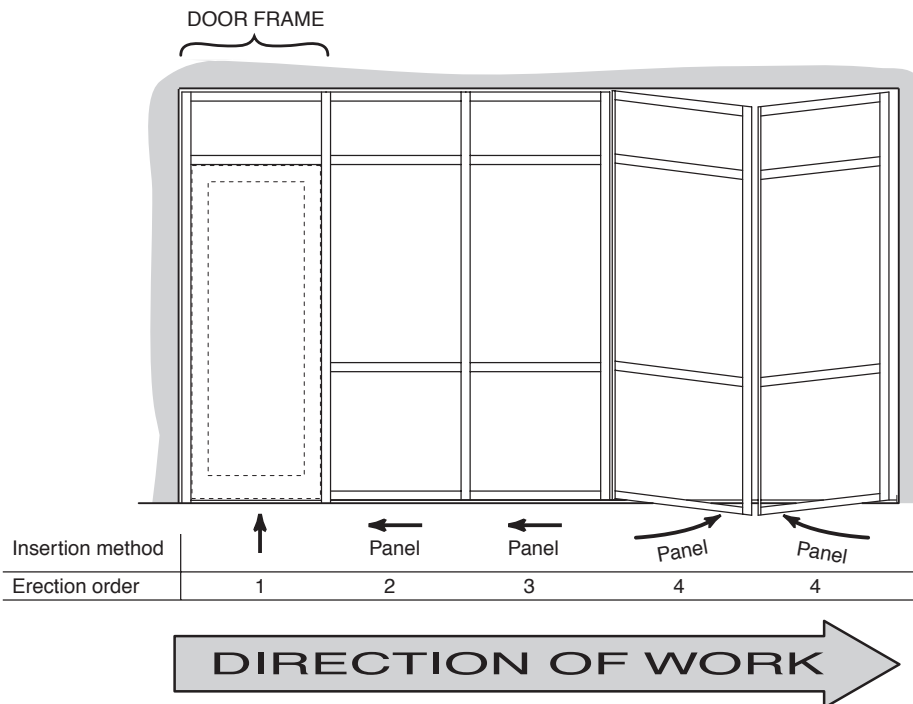

FRAME INSTALLATION (CONTINUED)

2. Installation with door

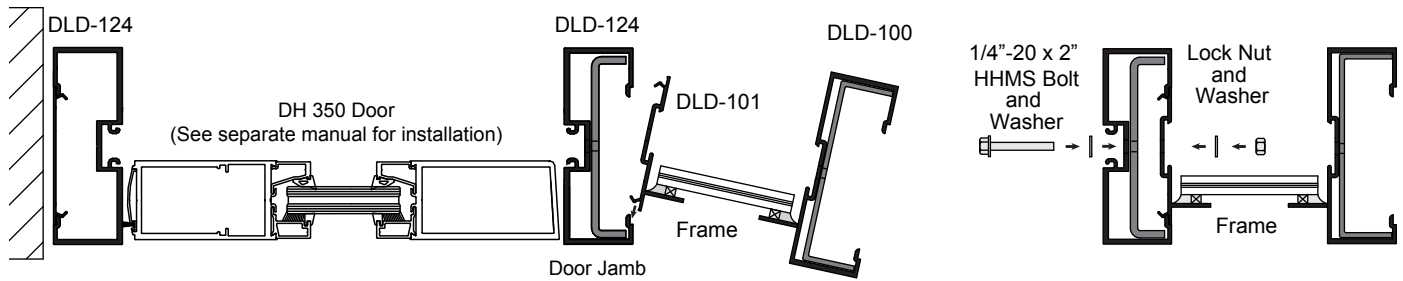

A. Hook DLD-101 exterior leg into DLD-124, rotate frame to snap into door jamb.

B. Secure at each hole location.

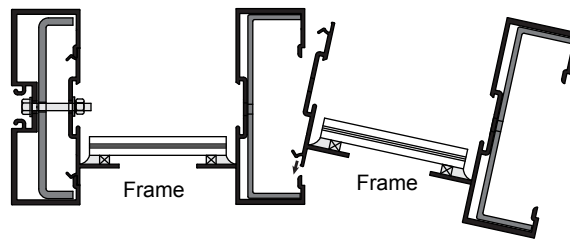

Repeat steps A and B to install remaining frames.

3. Installation without door

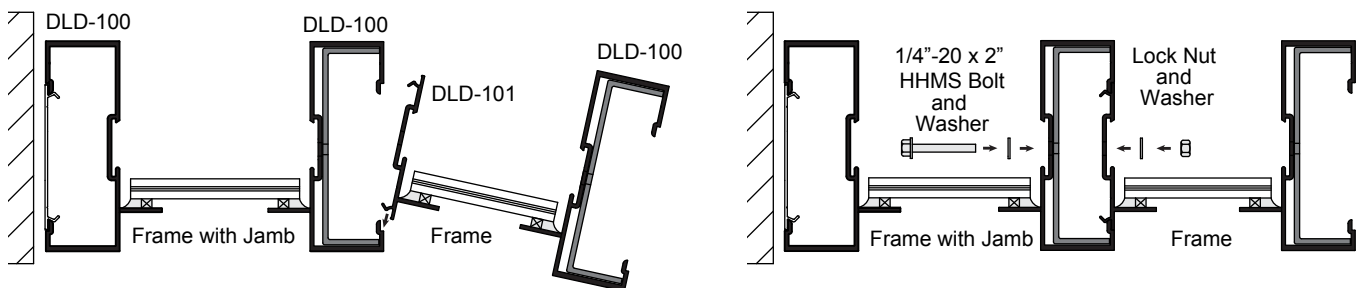

A. Position frames in opening. Hook DLD-101 exterior leg into DLD-100, rotate frame to snap into frame with jamb.

B. Secure at each anchor hole location.

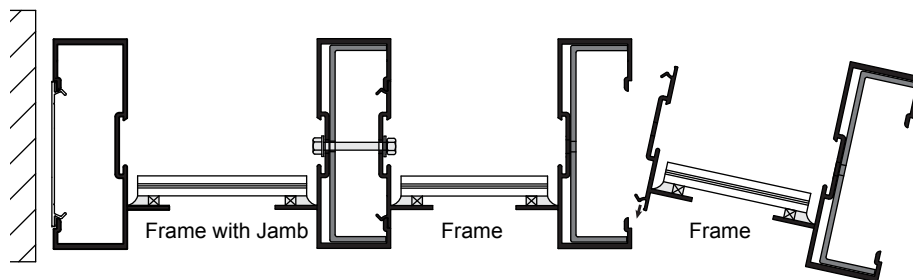

Repeat steps A and B to install remaining frames.

NOTE: Smaller elevations may be snapped together and then positioned into opening as single unit.

FRAME INSTALLATION (CONTINUED)

4. Anchor frame

Shim, level and square frame. Maintain 1/4" (6.4) shim space at head, sill and jambs. Ensure frame is level and plumb.

Anchor frame to structure using spacing and fasteners specified in CRL shop drawings. Always check for plumb, level and square while anchoring.

5. Seal perimeter.

Install backer rod around the perimeter of the frame, between frame and structure.

Use **Cat.No.95C** sealant for continuous perimeter seal between frame and structure.

Use **Cat.No.33S** Silicone Sealant to seal over heads of all anchor fasteners.

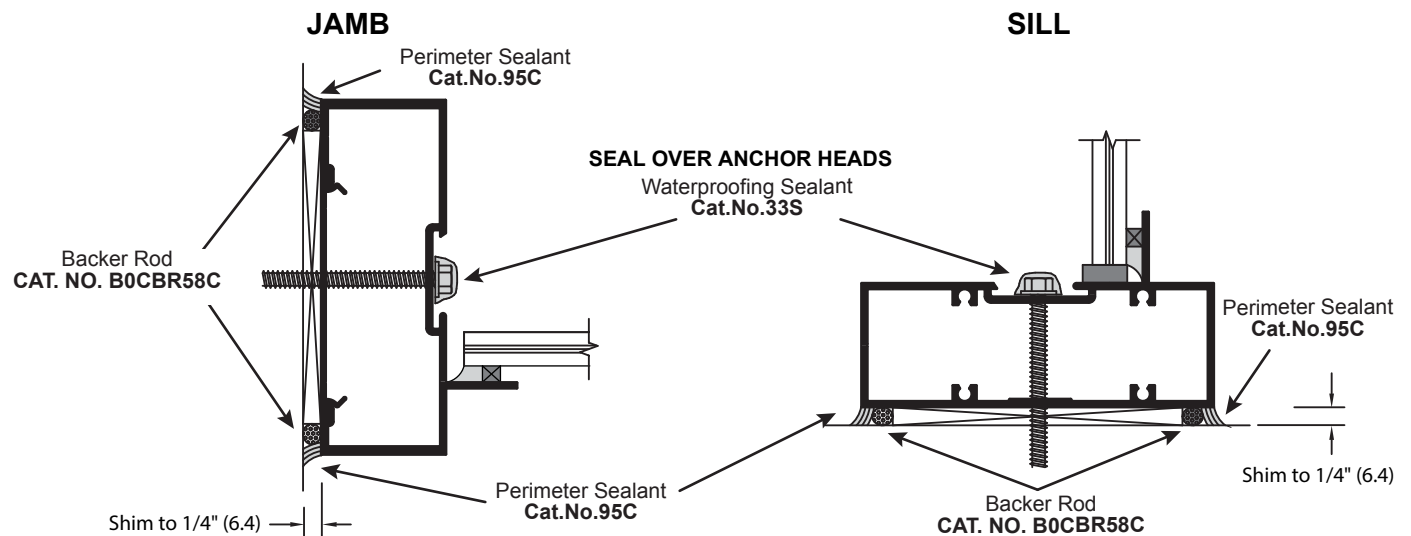

6. Install full length glass stops

Remove temporary glass stops and follow instructions on page 14 to replace with full length DLD-102 glass stops with glazing gaskets. Trim excess gasket at ends.

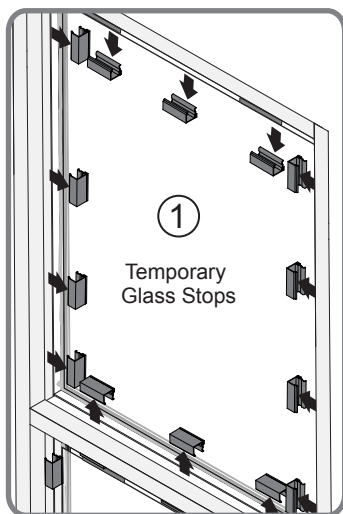

Remove temporary glass stops.



Install horizontal glass stops.
Note: Horizontals run through.



Install vertical glass stops.

SEAL EXTERIOR

The joint between the vertical and horizontal glazing legs must be sealed to ensure a water tight joint. Apply and tool sealant to all vertical to horizontal glazing leg joints and extend it to the glazing tape as shown.

1. Apply silicone cap bead around exterior glazing leg perimeter as shown. Make sure cap bead completely fills joint between glass and glazing leg.

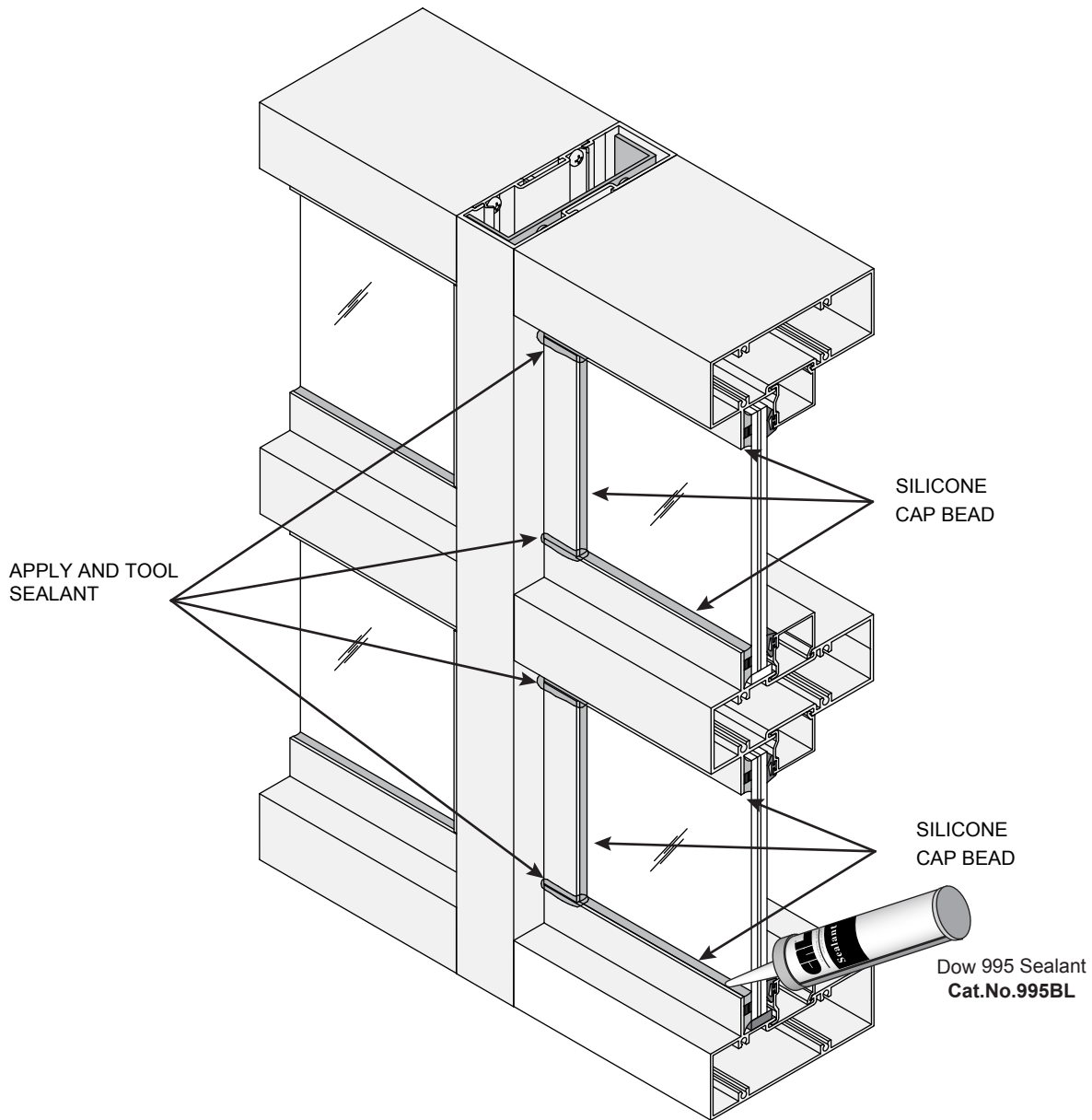



JOB SITE ESSENTIALS

Helpful Tools and Supplies for Installing CRL U.S. Aluminum Entrances, Storefronts, Windows, and Curtain Wall Systems



**CRL Black Dow Corning® 995
Silicone Structural Adhesive
CAT. NO. 995BL**



**CRL 1/4" x 1/2" Saint-Gobain/Norton
V2100 Thermalbond® Structural
Glazing Spacer Tape
CAT.NO. V210812**



**CRL 95C Silicone
Building Sealant
CAT. NO. 95C**



**CRL Makita® 18V Cordless Lithium
Ion 1/2" Hammer Driver Drill Kit
CAT.NO. LXPH03**



**CRL Gloves
CAT. NO. KF1TL**



**CRL Open Cell
Backer Rod
CAT. NO. B0CBR58C**



**CRL Backer Rod
Roller Tool
CAT. NO. SBRR**



**CRL Glass Cleaner
CAT. NO. 1973**



**CRL Glass Wipes
CAT. NO. 1550**

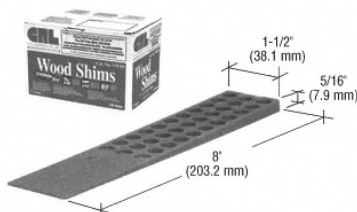

**CRL Wood Composite Shims -
Case of 288
CAT. NO. BWCS8**



**CRL Soft-Face Power Hitter
CAT. NO. ST57532**



**CRL Vacuum Cup
CAT. NO. S7950**