

INSTALLATION INSTRUCTIONS

SIDELITE ASSEMBLY

SERIES 900 TERRACE DOOR AND SERIES 925 PATIO DOOR



Phone: (800) 262-5151 • Fax: (866) 262-3299
crlaurence.com • usalum.com • crl-arch.com

HANDLING, STORAGE, AND PROTECTION OF ALUMINUM

The following precautions are recommended to protect the material against damage. Following these precautions will help ensure early acceptance of your products and workmanship.

A. HANDLE CAREFULLY.

All aluminum materials at job site must be stored in a safe place, well removed from possible damage by other trades. Cardboard wrapped or paper interleaved materials must be kept dry.

B. CHECK ARRIVING MATERIALS.

Check for quantity counts and keep records of where various materials are stored.

C. KEEP MATERIALS AWAY FROM WATER, MUD, AND SPRAY.

Prevent cement plaster or other materials from damaging the finish.

D. PROTECT THE MATERIALS AFTER ERECTION.

Protect erected frame with polyethylene or canvas splatter screen. Cement, plaster, terrazzo, other alkaline solutions, and acid based materials used to clean masonry are harmful to the finish. If any of these materials come in contact with the aluminum, immediately remove with water and mild soap.

ORDER OF ASSEMBLY AND INSTALLATION

Handling, Storage, and Protection of Aluminum	02
General Installation Notes	03
Sidelite Fabrication	04 - 05
Sidelite Assembly	06
Sidelite Attachment to Door	07
Sidelite Attachment to Door with Transom	08
Sidelite Glazing	09

The rapidly changing technology within the architectural aluminum products industry demands that C.R. Laurence/U.S. Aluminum reserve the right to revise, discontinue, or change any product line, specification, or electronic media without prior written notice.

NOTE: Dimensions in parentheses () are millimeters unless otherwise noted.

GENERAL INSTALLATION NOTES

RECOMMENDED GUIDELINES FOR ALL INSTALLATIONS:

- 1. REVIEW CONTRACT DOCUMENTS.** Check shop drawings, installation instructions, architectural drawings, and shipping lists to become thoroughly familiar with the project. The shop drawings take precedence and include specific details for the project. Note any *field verified* notes on the shop drawings prior to installing. The installation instructions are of a general nature and cover most conditions.
- 2. INSTALLATION.** All materials are to be installed plumb, level, and true. Install operable windows pre-glazed only.
- 3. BENCH MARKS.** All work should start from bench marks and/or column lines as established by the architectural drawings and the general contractor with guaranteed accuracy. Working from these datum points and lines determine:
 - a) The plane of the wall in reference to offset lines provided on each floor.
 - b) The finish floor lines in reference to bench marks on the outer building columns.
 - c) Mullion spacing from both ends of masonry opening to prevent dimensional build-up of daylight opening.
- 4. FIELD WELDING.** All field welding must be adequately shielded to avoid any splatter on glass or aluminum. Results will be unsightly and/or structurally unsound. Advise general contractor and other trades accordingly. All field welds of steel anchors must receive touch-up paint (zinc chromate) to avoid rust.
- 5. SURROUNDING CONDITIONS.** Make certain that construction which will receive your materials is in accordance with the contract documents. If not, notify the general contractor in writing and resolve differences before proceeding with work.
- 6. ISOLATION OF ALUMINUM.** Aluminum to be placed in direct contact with uncured masonry or incompatible materials should be isolated with a heavy coat of zinc chromate or bituminous paint.
- 7. SEALANTS.** Sealants must be compatible with all materials with which they have contact, including other sealant surfaces. Consult with sealant manufacturer for recommendations relative to joint size, shelf life, compatibility, cleaning/priming, tooling, adhesion, etc. It is the responsibility of the **Glazing Contractor** to submit a statement from the sealant manufacturer indicating that glass and glazing materials have been tested for compatibility and adhesion with glazing sealants, and interpreting test results relative to material performance, including recommendations for primers and substrate preparation required to obtain adhesion. The chemical compatibility of all glazing materials and framing sealants with each other and with like materials used in glass fabrication must be established. This is required on every project.
- 8. FASTENING.** Within the body of these instructions "fastening" means any method of securing one part to another or to adjacent materials. Only those fasteners used within the system are specified in these instructions. Due to the varying perimeter conditions and performance requirements, perimeter and anchor fasteners are not specified in these instructions. For perimeter and anchor fasteners refer to the shop drawings or consult the fastener supplier.
- 9. BUILDING CODES.** Due to the diversity in state/provincial local, and federal laws and codes that govern the design and application of architectural products, it is the responsibility of the individual architect, owner, and installer to assure that products selected for use on projects comply with all the applicable building codes and laws. U.S. Aluminum exercises no control over the use or application of its products, glazing materials, and operating hardware and assumes no responsibility thereof.
- 10. EXPANSION JOINTS.** Expansion joints and perimeter seals shown in these instructions and in the shop drawings are shown at normal size. Actual dimensions may vary due to perimeter conditions and/or difference in metal temperature between the time of fabrication and the time of installation. Gaps between expansion members should be based on temperature at time of installation.
- 11. WATER HOSE TEST.** As soon as a representative amount of the wall has been glazed (500 square feet or 46.5 m²) a water hose test should be conducted in accordance with AAMA 501.2 specifications to check the installation. On all jobs the hose test should be repeated every 500 square feet (46.5 m²) during the glazing operation.
- 12. COORDINATION WITH OTHER TRADES.** Coordinate with the general contractor any sequence of the installation that involves other trades in the project (i.e. framing, fire proofing, back-up walls, partitions, ceilings, mechanical ducts, converters, etc.).
- 13. CARE AND MAINTENANCE.** Final cleaning of exposed aluminum surfaces should be done in accordance with AAMA 609.1 for anodized aluminum and 610.1 for painted aluminum.

SIDELITE FABRICATION

1. Identify the components of the Terrace Door/Patio Door Sidelite. See **DETAIL A**

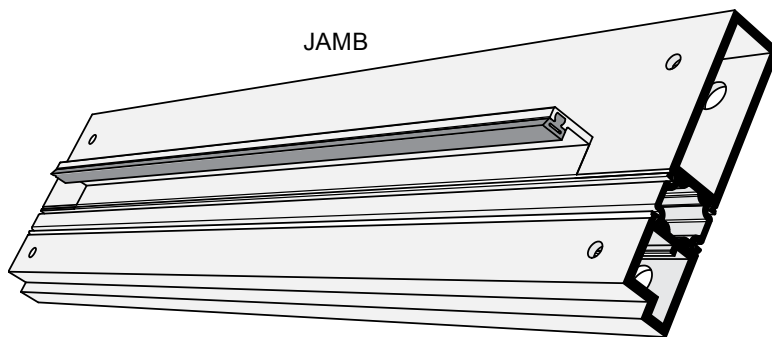
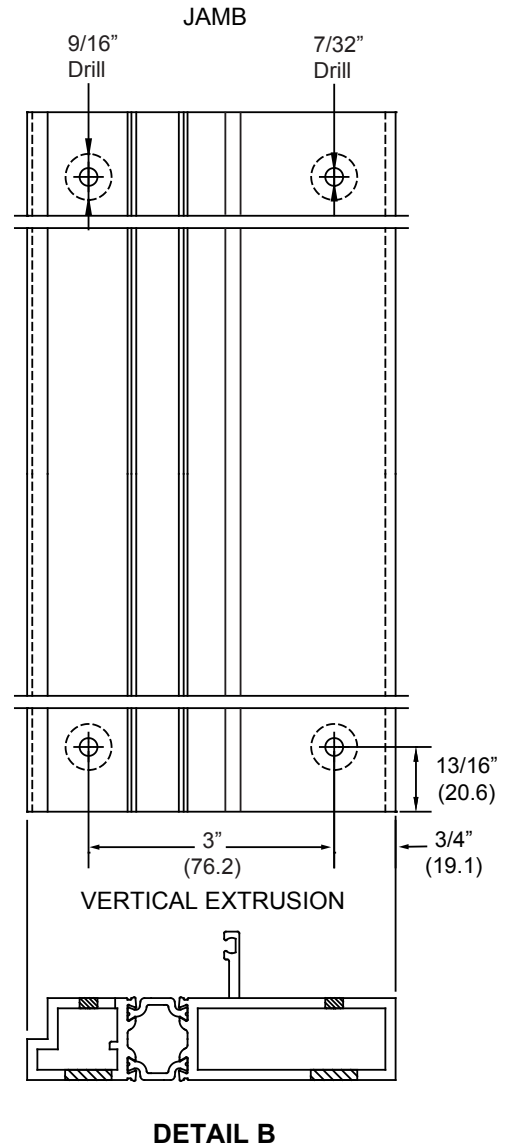
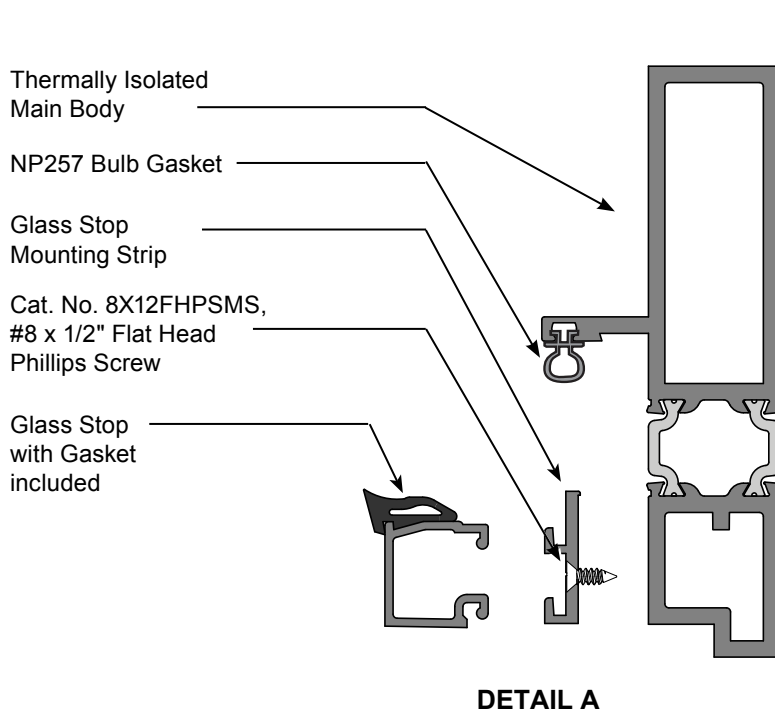

2. Drill 9/16" access holes and 7/32" screw holes on each end of all vertical members. See **DETAIL B**.

3. Notch each end of the vertical members as shown in **DETAIL C**.

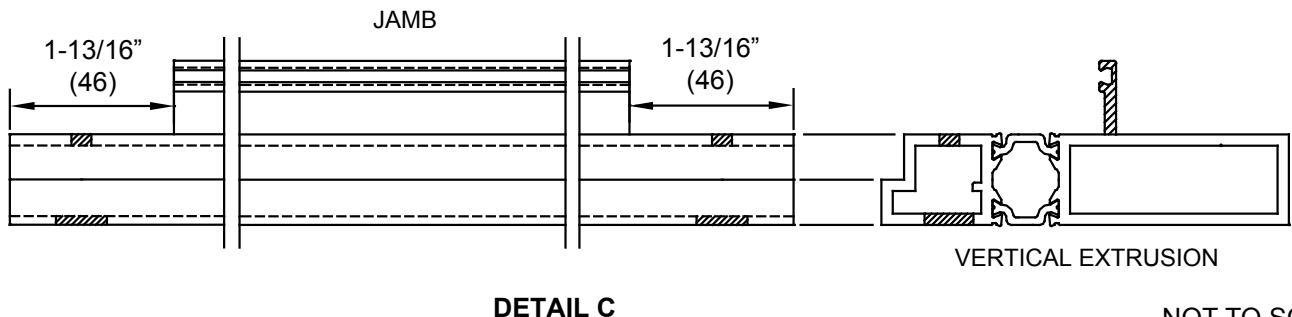

NOT TO SCALE

SIDELITE FABRICATION (CONTINUED)

4. Notch the tabs on each end of all Glass Stops and Mounting Strips at sills, forming a weep hole when assembled.

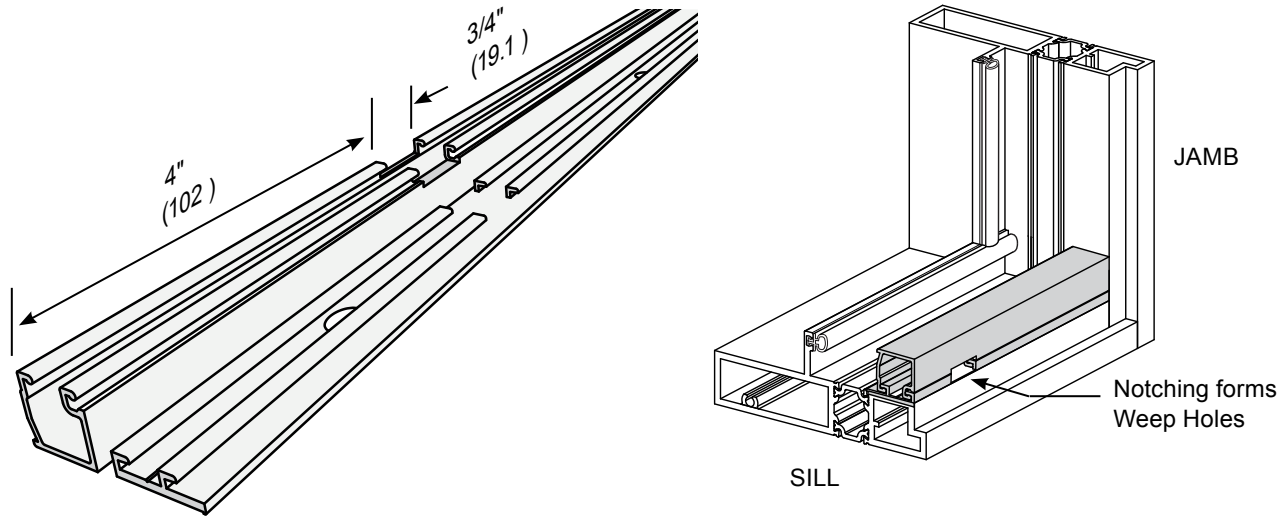

5. Notch each end of the horizontal members as shown in **DETAIL D**.

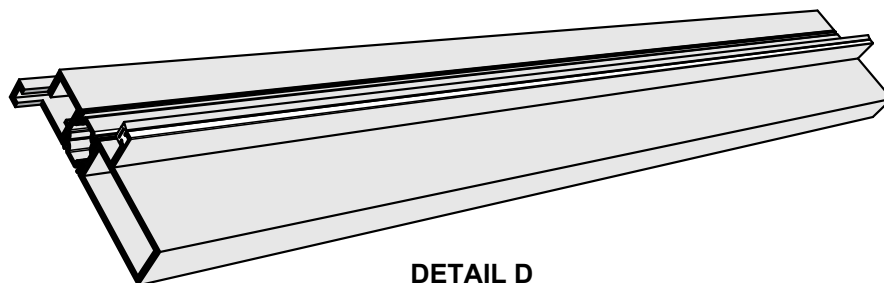
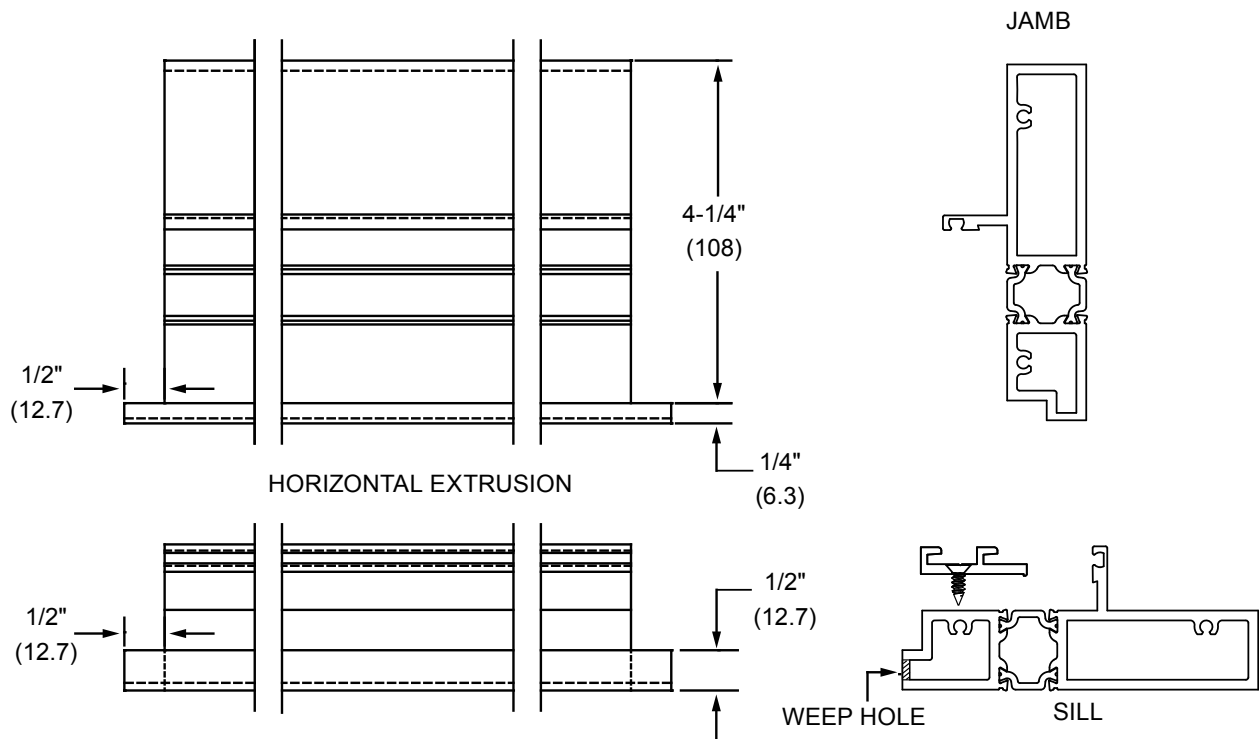

NOT TO SCALE

SIDELITE ASSEMBLY

1. Assemble the vertical and horizontal members using Cat. No. 10X1HWSMS, #10 x 1" Hex Washer Head Screws. Apply CRL RTV408 Sealant to all ends of the horizontals before assembly. See **DETAIL E**.

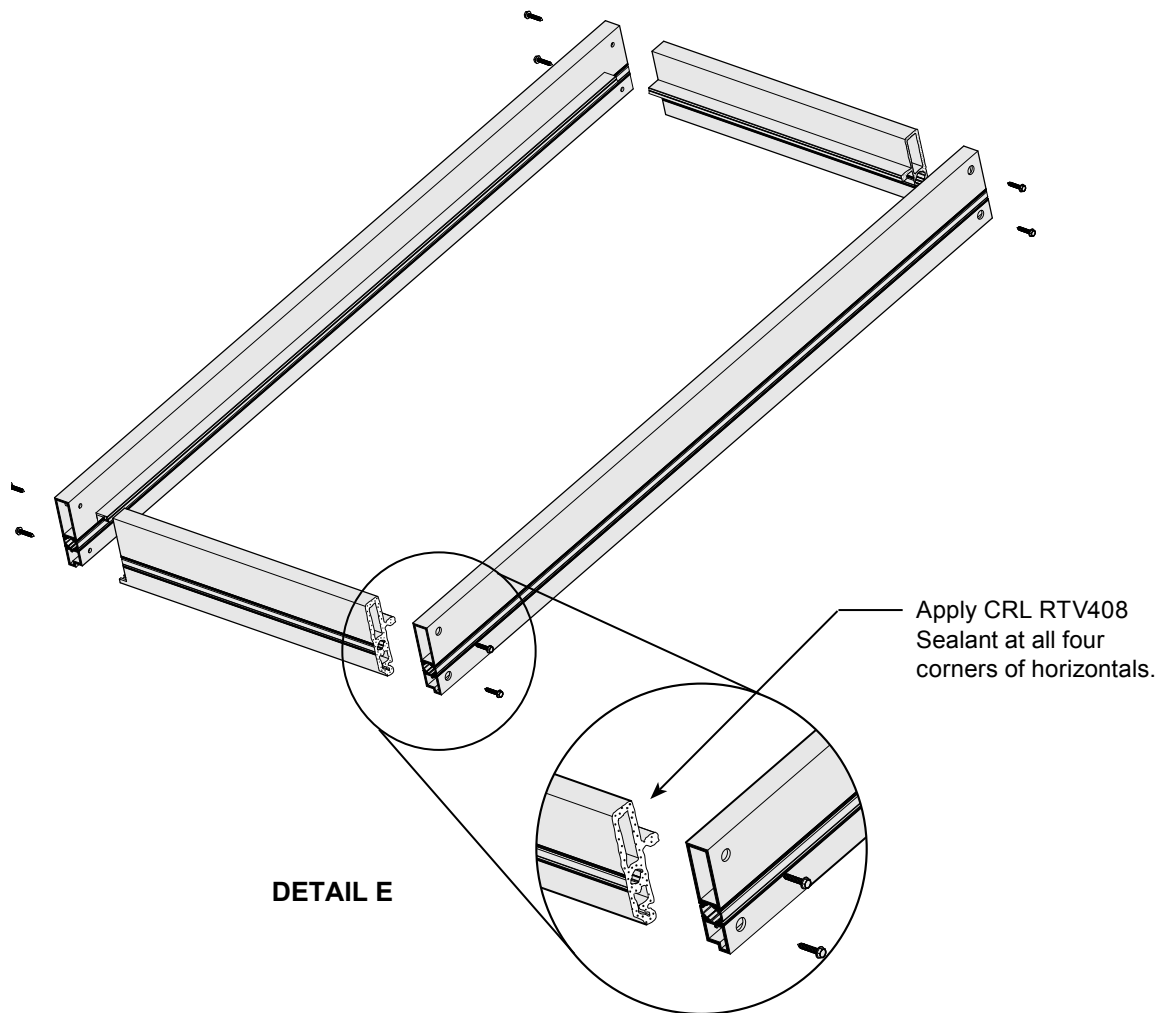

2. Install Corner Caps. Apply CRL RTV408 Sealant to top and bottom of jambs and EC96499 End Dams as shown in **DETAIL F**. Secure with Cat. No. 8X1FHPSMS Flat Head Phillips Screw. Seal over screw head.

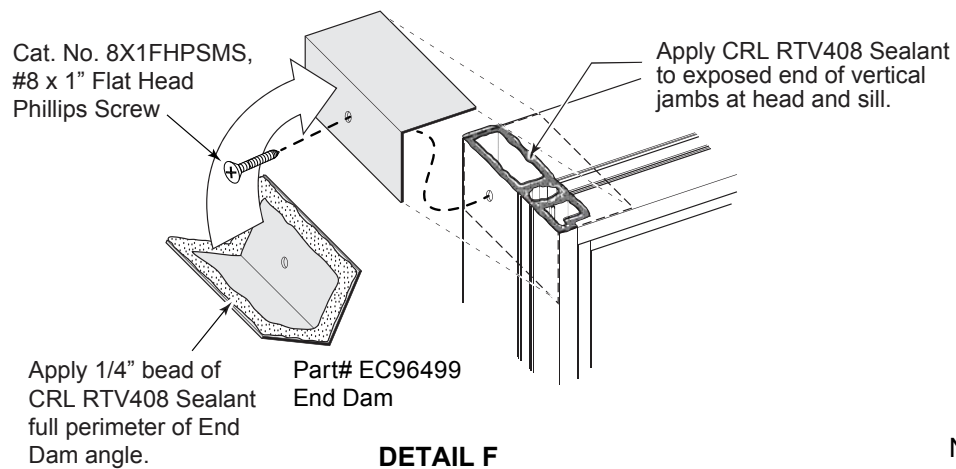

SIDELITE ATTACHMENT TO DOOR

1. Run a perimeter bead on the adjacent door jamb with CRL RTV408 Sealant. **DETAIL G**
2. Align and clamp the sidelite mullion to the door strike jamb in place.
3. Going through the door frame, attach the sidelite with #10 x 1-1/2" Flat Head Phillips Screws, 12" O.C. **See DETAIL G.**

NOTE: The screw heads should be countersunk and flush with the glazing channel. **See DETAIL H.**

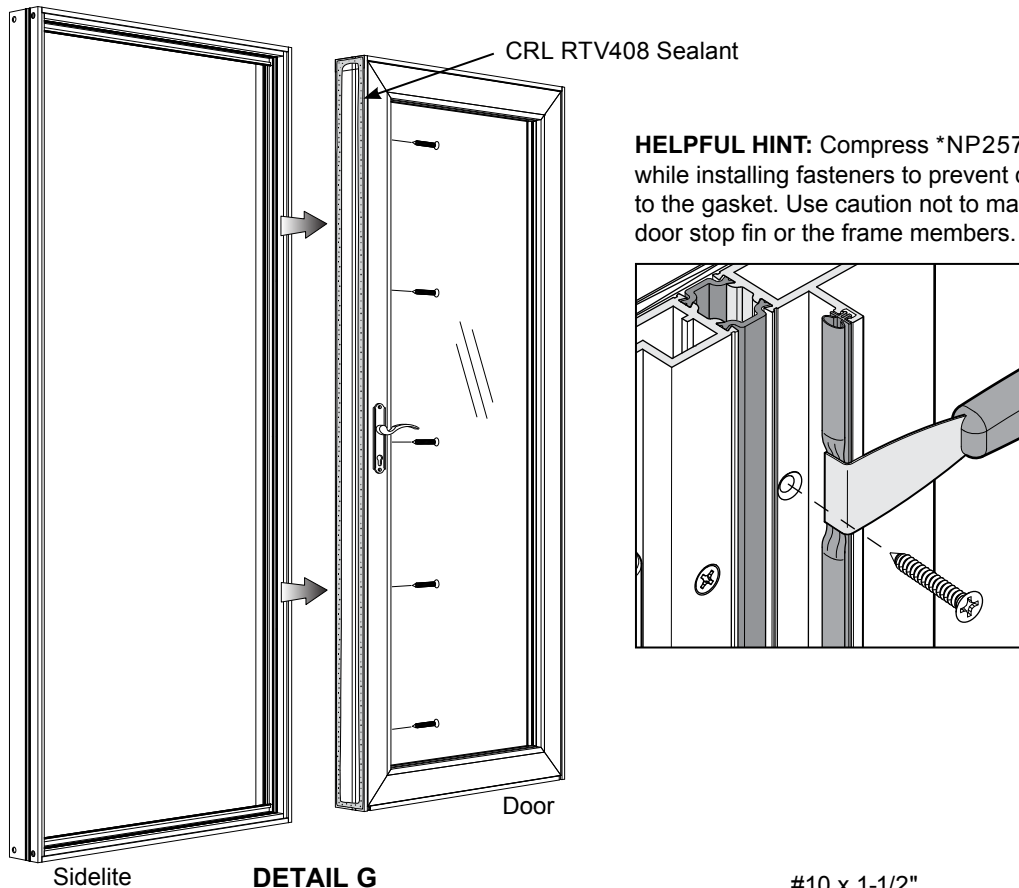

A continuous bead of CRL RTV408 Sealant around the full perimeter

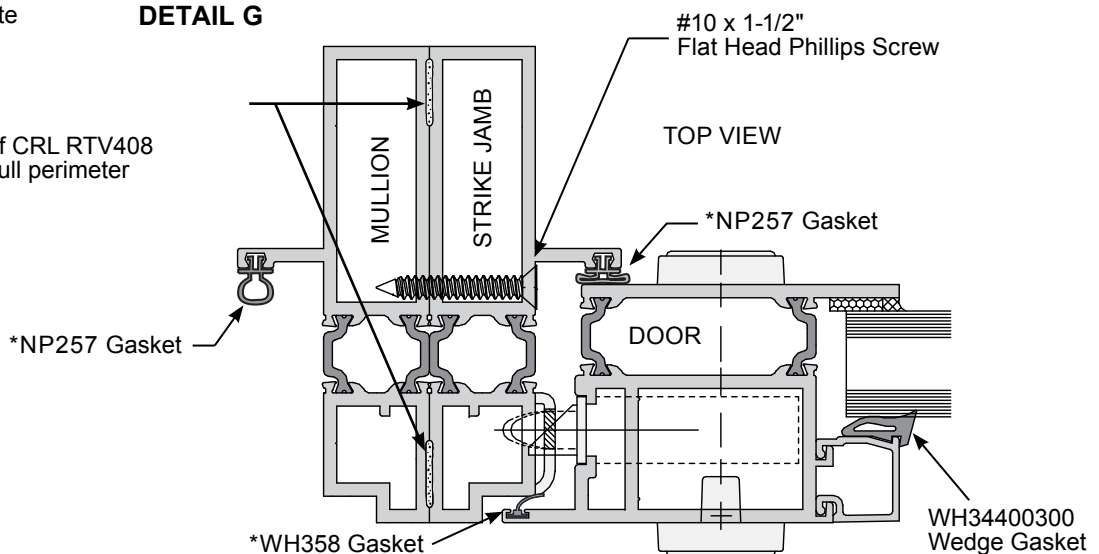

* In the event a replacement gasket is required, the full door perimeter seal should be replaced.

NOT TO SCALE

SIDELITE ATTACHMENT TO DOOR WITH TRANSOM

4. Apply CRL RTV408 Sealant to all mating surfaces. See **DETAIL I**.
5. Align and clamp the Sidelite in place.
6. Attach all components with #10 x 1-1/2" Flat Head Phillips Screws. Seal over all screw heads.

NOTE: The screw heads should be countersunk and flush with the glazing channel. See **DETAIL J**.

NOTE: Some conditions may require sill pan flashing within door and sidelite opening. Consult approved shop drawings for any flashing installation requirements.

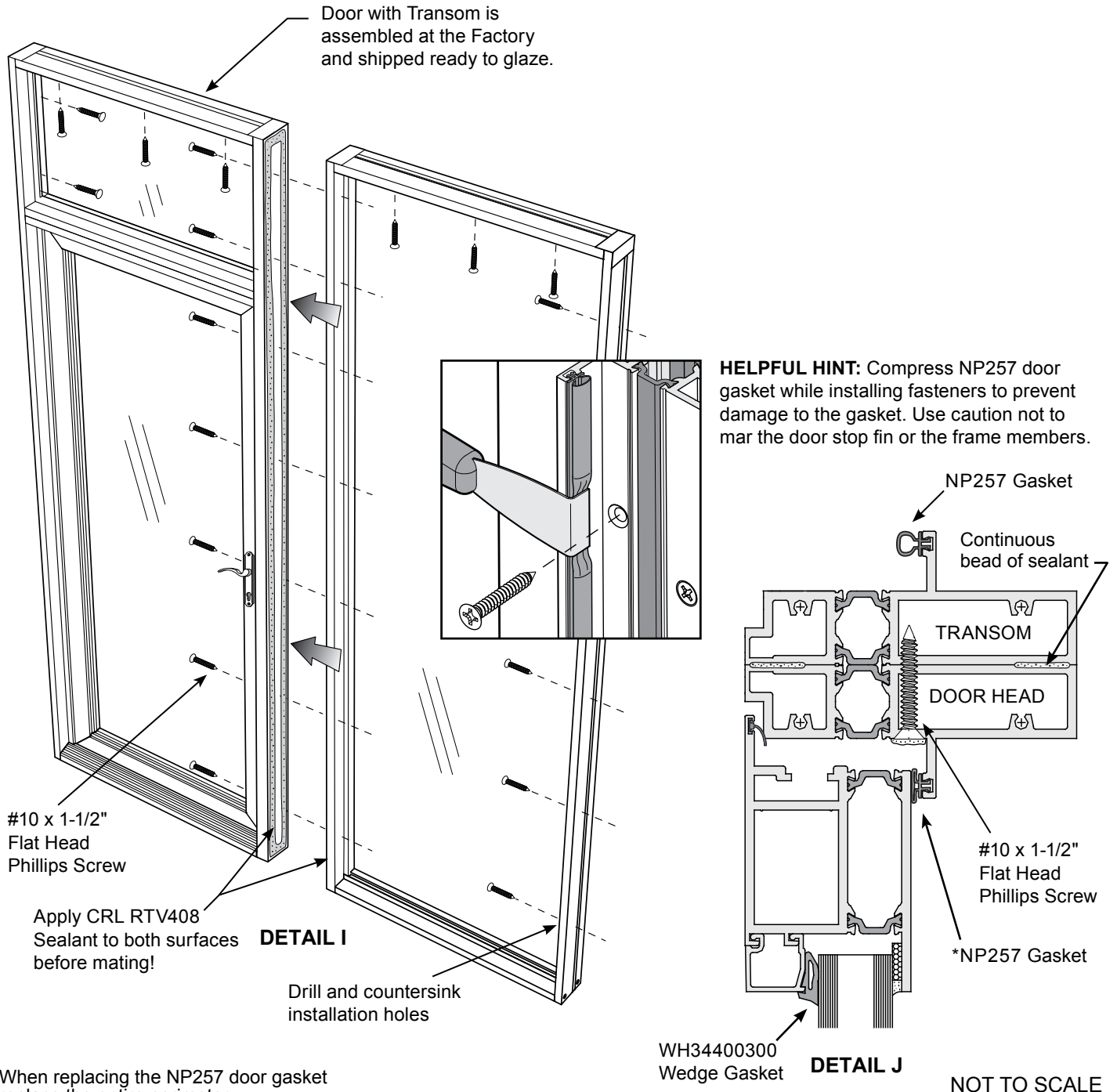

* When replacing the NP257 door gasket replace the entire perimeter.

SIDELITE GLAZING

1. **DETAIL K** illustrates the horizontal members of a sidelite frame before glazing.
2. The illustration in **DETAIL L** shows the same sidelite now **completely glazed**.

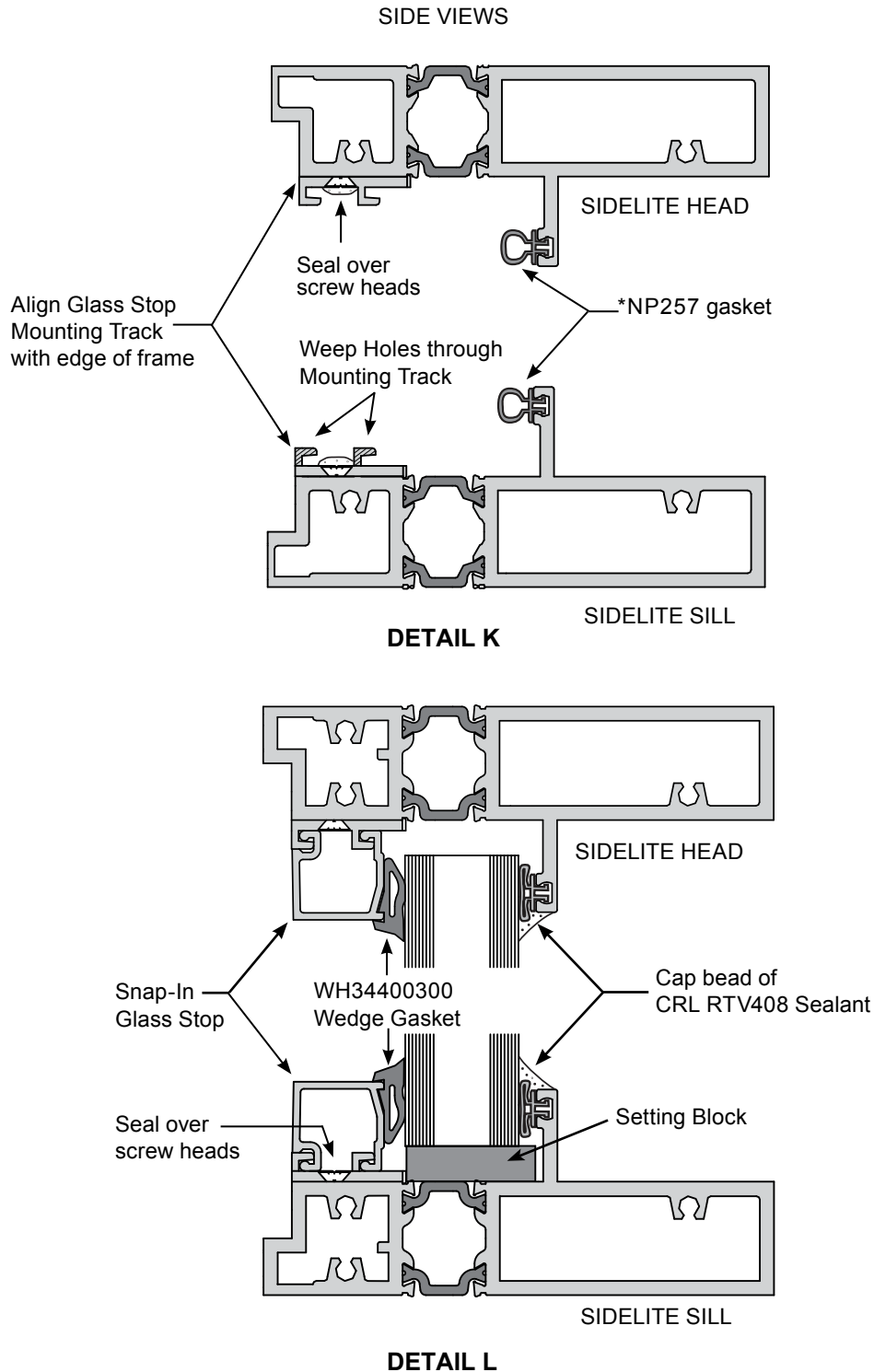

* When replacing the NP257 door gasket replace the entire perimeter

NOT TO SCALE