

C.R. LAURENCE CO., INC.

CRL Core Mount Frameless Windscreen Clamp Instructions

Typical Installation of a Core Mount Frameless Windscreen

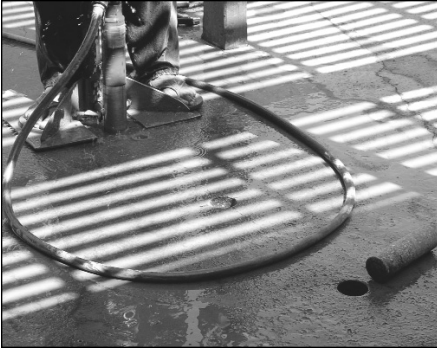

1. Mark the hole locations for core drilling based on approved drawings, or from glass panel layout, including panel spacing.



2. With the glass laying flat, position the Clamp on the glass panel. Then insert gaskets equally on each side of the glass.



3. Use a square to align the Clamp and gaskets, then secure in place by tightening the screws. Now screw in the threaded retaining stud.



4. Place setting blocks just inside of each cored hole, then insert the threaded retaining stud into the hole. Keep bottom of Clamp portion equal to or above floor level. If Garnish Rings are used, install prior to setting the panel.



5. Plumb the glass panels and check spacing of gaps between panels. Wood blocks between panels can be used for uniformity of gaps.

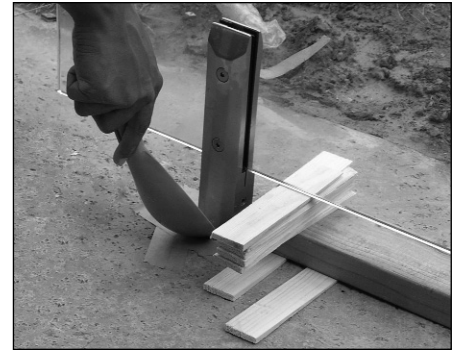

6. Pouring Kwixset® Expanding Cement in the hole will secure the Clamp. If using a Garnish Ring be sure it is in place before pouring.



7. Panels can be strengthened with the addition of Mall Glass Clamps between panels, or by using Top Cap Rails.



8. Secure the Garnish Rings in place with silicone sealant.



9. Clean the glass panels thoroughly to finish the job.

AFWC1

CRL ONE-PIECE
CORE MOUNT FRAMELESS
WINDSCREEN CLAMP
Typical Fabrication Guidelines
for Frameless Glass Core Mount
Brackets

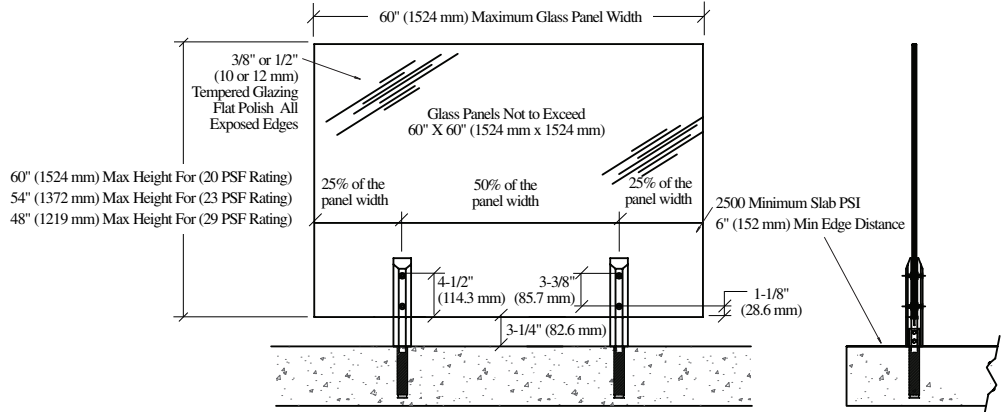

AFWC1 TOP MOUNT FABRICATION GUIDELINES

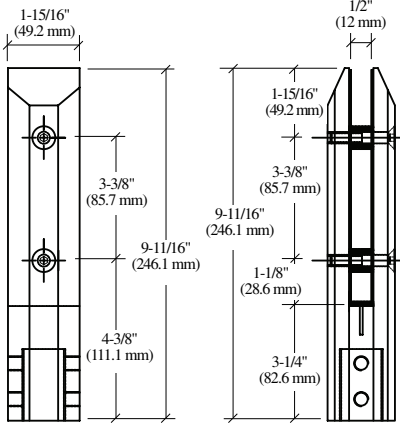

FRONT VIEW

SIDE VIEW

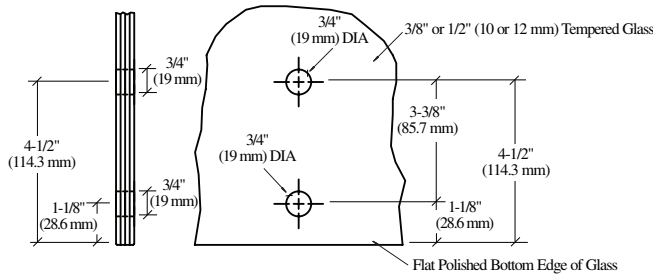

GLASS FABRICATION REQUIREMENTS

AFWC3

CRL THREE-PIECE
CORE MOUNT FRAMELESS
WINDSCREEN CLAMP
Typical Fabrication Guidelines
for Frameless Glass Core Mount
Brackets

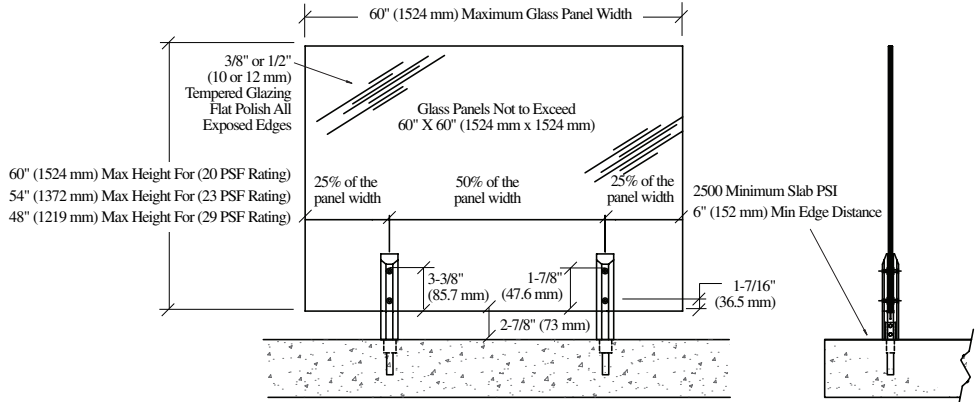

AFWC3 TOP MOUNT FABRICATION GUIDELINES

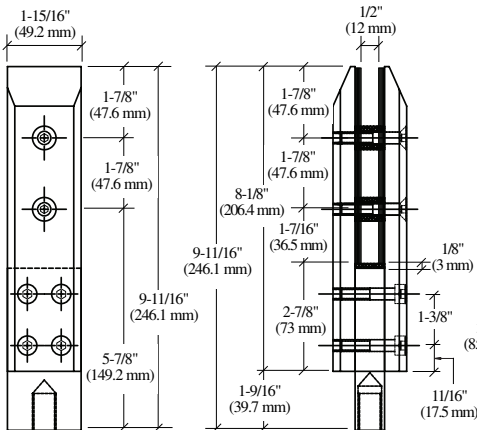

FRONT VIEW

SIDE VIEW

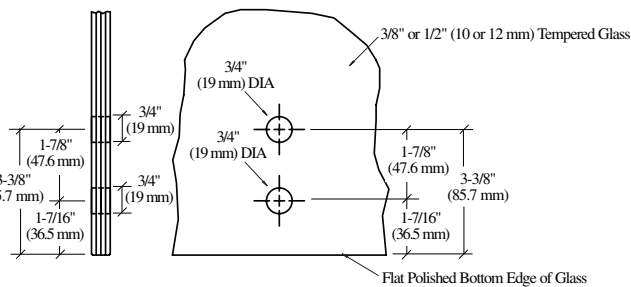

GLASS FABRICATION REQUIREMENTS