

# INSTALLATION INSTRUCTIONS

# ELEPHANT DOOR SYSTEMS SERIES E1200



---

Phone: (800) 262-5151 • Fax: (866) 262-3299  
crlaurence.com • usalum.com • crl-arch.com

---

## **TABLE OF CONTENTS**

<u>SUBJECT</u>	<u>PAGE</u>
GENERAL INSTALLATION NOTES .....	03
INSTALLING THE TOP HEAD TRACK .....	04
INSTALLING THE RECESSED SILL .....	05-06
MOUNTING THE WINDLOAD ANCHORS - FIXED PANELS .....	07
INSTALLING THE FIXED PANELS WITH THRESHOLD .....	08
INSTALLING FIXED PANELS WITHOUT SUBSILLS .....	09
INSTALLING FIXED PANELS WITH THE FF450 SUBSILL .....	10
INSTALLING THE SLIDING PANELS .....	11
EXTERIOR GLAZING .....	12
OPTIONAL POWER OPERATED DOORS .....	13-14
SITE PREPARATION DIAGRAM .....	15

The rapidly changing technology within the architectural aluminum products industry demands that U.S. Aluminum reserve the right to revise, discontinue or change any product line, specification or electronic media without prior written notice.

# GENERAL INSTALLATION NOTES

## Recommended Guidelines for All Installations:

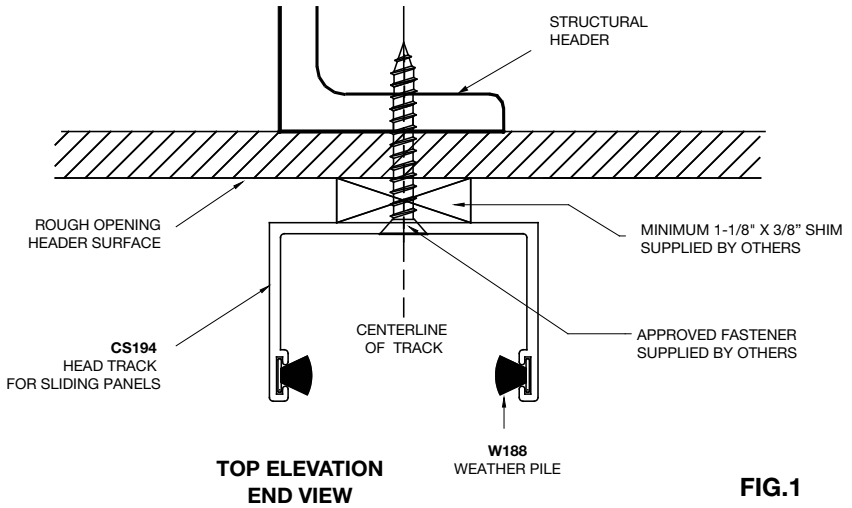
1. **REVIEW CONTRACT DOCUMENTS.** Check shop drawings, installation instructions, architectural drawings, and shipping lists to become thoroughly familiar with the project. The shop drawings take precedence and include specific details for the project.

Note any *field verified* notes on the shop drawings prior to installing. The installation instructions are of a general nature and cover most conditions.

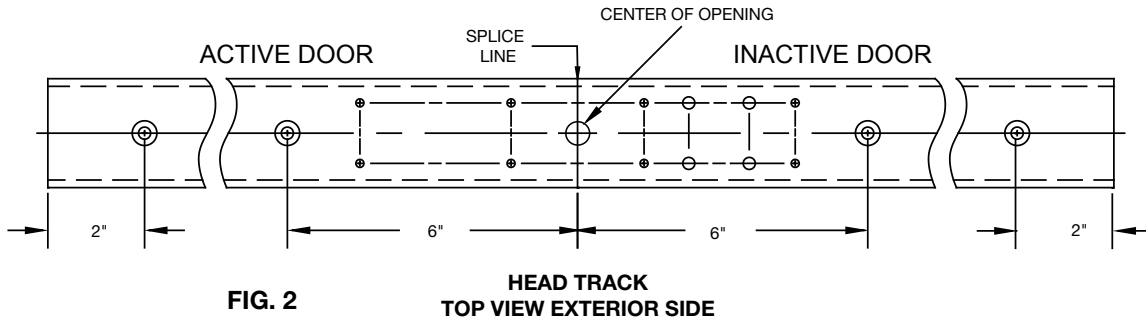
2. **INSTALLATION.** All materials are to be installed plumb, level, and true. Install operable windows preglazed only.
3. **BENCH MARKS.** All work should start from bench marks and/or column lines as established by the architectural drawings and the general contractor with guaranteed accuracy. Working from these datum points and lines determine:
  - a) The plane of the wall in reference to offset lines provided on each floor.
  - b) The finish floor lines in reference to bench marks on the outer building columns.
  - c) Mullion spacing from both ends of masonry opening to prevent dimensional build-up of daylight opening.
4. **FIELD WELDING.** All field welding must be adequately shielded to avoid any splatter on glass or aluminum. Results will be unsightly and/or structurally unsound. Advise general contractor and other trades accordingly. All field welds of steel anchors must receive touch-up paint (zinc chromate) to avoid rust.
5. **SURROUNDING CONDITIONS.** Make certain that construction which will receive your materials is in accordance with the contract documents. If not, notify the general contractor in writing and resolve differences before proceeding with work.
6. **ISOLATION OF ALUMINUM.** Aluminum to be placed in direct contact with uncured masonry or incompatible materials should be isolated with a heavy coat of zinc chromate or bituminous paint.
7. **SEALANTS.** Sealants must be compatible with all materials with which they have contact, including other sealant surfaces. Consult with sealant manufacturer for recommendations relative to joint size, shelf life, compatibility, cleaning/priming, tooling, adhesion, etc. It is the responsibility of the glazing contractor to submit a statement from the sealant manufacturer indicating that glass and glazing materials have been tested for compatibility and adhesion with glazing sealants, and interpreting test results relative to material performance, including recommendations for primers and substrate preparation required to obtain adhesion. The chemical compatibility of all glazing materials and framing sealants with each other and with like materials used in glass fabrication must be established. This is required on every project.
8. **FASTENING.** Within the body of these instructions, "fastening" means any method of securing one part to another or to adjacent materials. Only those fasteners used within the system are specified in these instructions. Due to the varying perimeter conditions and performance requirements, perimeter and anchor fasteners are not specified in these instructions. For perimeter and anchor fasteners refer to the shop drawings or consult the fastener supplier.
9. **BUILDING CODES.** Due to the diversity in local state/provincial, and federal laws and codes that govern the design and application of architectural products it is the responsibility of the individual architect, owner, and installer to assure that products selected for use on projects comply with all the applicable building codes and laws. U.S. Aluminum exercises no control over the use or application of its products, glazing materials, and operating hardware, and assumes no responsibility thereof.
10. **EXPANSION JOINTS.** Expansion joints and perimeter seals shown in these instructions and in the shop drawings are shown at normal size. Actual dimensions may vary due to perimeter conditions and/or difference in metal temperature between the time of fabrication and the time of installation. Gaps between expansion members should be based on temperature at time of installation.
11. **WATER HOSE TEST.** As soon as a representative amount of the wall has been glazed (500 square feet or 46.5 m<sup>2</sup>) a water hose test should be conducted in accordance with AAMA 501.2 specifications to check the installation. On all jobs the hose test should be repeated every 500 square feet (46.5 m<sup>2</sup>) during the glazing operation.
12. **COORDINATION WITH OTHER TRADES.** Coordinate with the general contractor any sequence with other trades which offset curtain wall installation (i.e. fire proofing, back-up walls, partitions, ceilings, mechanical ducts, converters etc.).
13. **CARE AND MAINTENANCE.** Final cleaning of exposed aluminum surfaces should be done in accordance with AAMA 609.1 for anodized aluminum and AAMA 610.1 for painted aluminum.

**STEP 1: INSTALLING THE TOP HEAD TRACK**

1. Inspect the underside of the rough opening header surface for irregularities. It should be level, smooth and ready to accept the system hardware. Refer to the Shop Drawings for the location dimensions of the Top Sliding Panel Track.
2. Mark a line across the bottom of the header surface from side-to-side on which to locate the centerline of the Head Track as shown above (FIG. 1). Next, place a centerline mark on the header between the two vertical walls of the opening. Locate the two halves of the Head Track and lay them out on the floor directly below the header with the legs down. The prepped ends go together to form a splice. You will need to determine the correct orientation of the sliding panels from your shop drawings (i.e.: Key Lock will be on the Active Door side and the Flush Bolts will be on the inactive side) (FIG. 2).

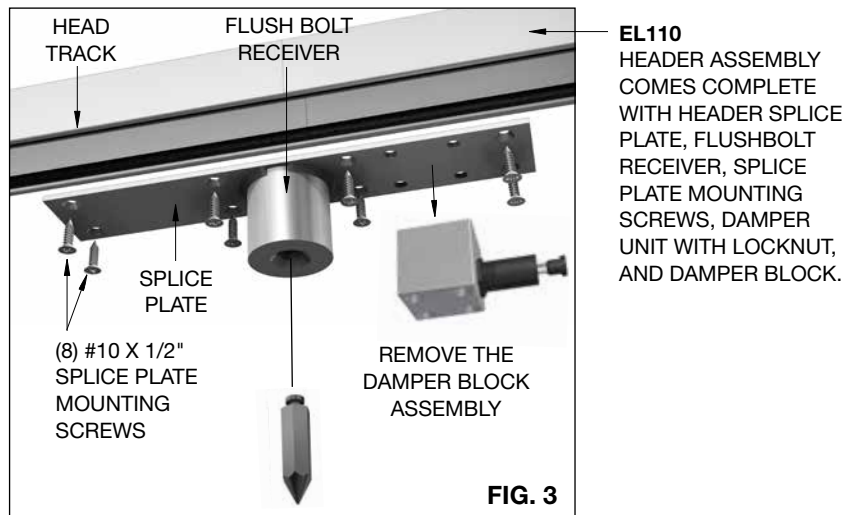


**FIG. 1**



**FIG. 2**

3. Proceed to attach the two track halves to the header surface using the approved fasteners and shims maintaining a level installation. Be sure that the two halves are tight at the splice and straight across.
4. Remove the Damper Block and attach the Splice Plate using (8) #10 X 1/2" flat head sheet metal screws. Fasten the screws through the Splice Plate and into the structural header. The Flush Bolt Receiver should be centered across the Head Track splice as it is inserted up inside (FIG. 3).



**FIG. 3**

## STEP 2 : INSTALLING THE RECESSED SILL

1. From the center of the Flush Bolt Receiver, drop a plumb bob directly down to the floor. This will indicate the location of the bottom flushbolt hole in the Recessed Track. Place a mark on the floor (**FIG. 4**).
2. Next, mark the floor directly below each end of the Head Track along the same center line as above.
3. Snap a chalk line on the floor between the two end marks. It should pass through the center flush bolt hole location in Step 1. Lay the Bottom Recessed Sill on the floor directly below and parallel to the Head Track. Align the Bottom Flush Bolt hole and check with the plumb bob (**FIG. 4**).
4. Mark around the perimeter of the sill.
5. Cut a trench in the floor surface a minimum of 7" in width by 1" deep, adding at least 1/4" to each end (**FIG. 6**).



FIG. 4

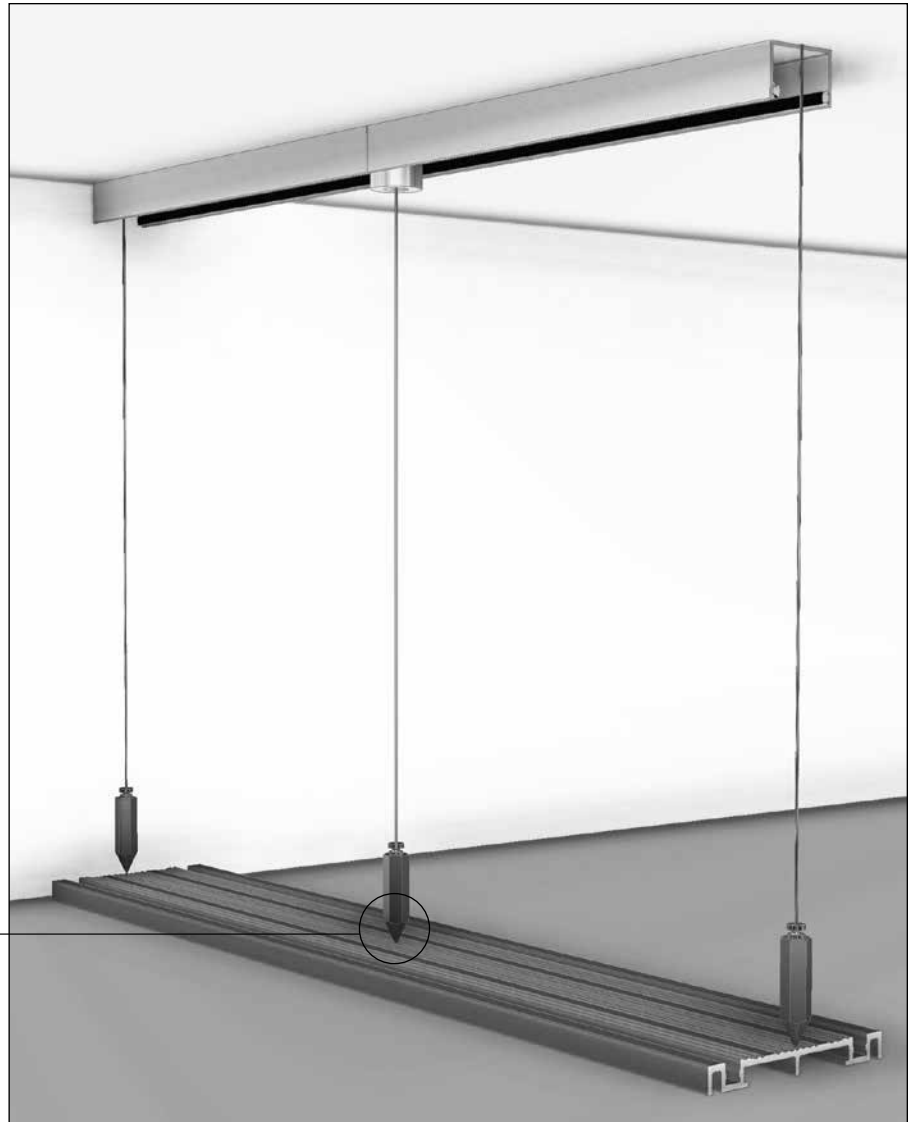
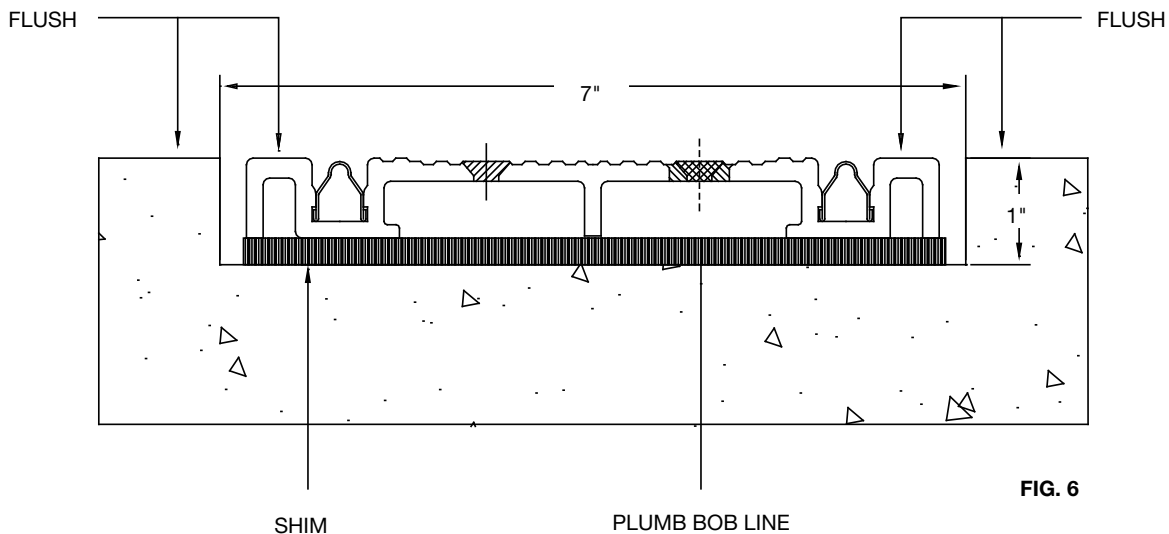


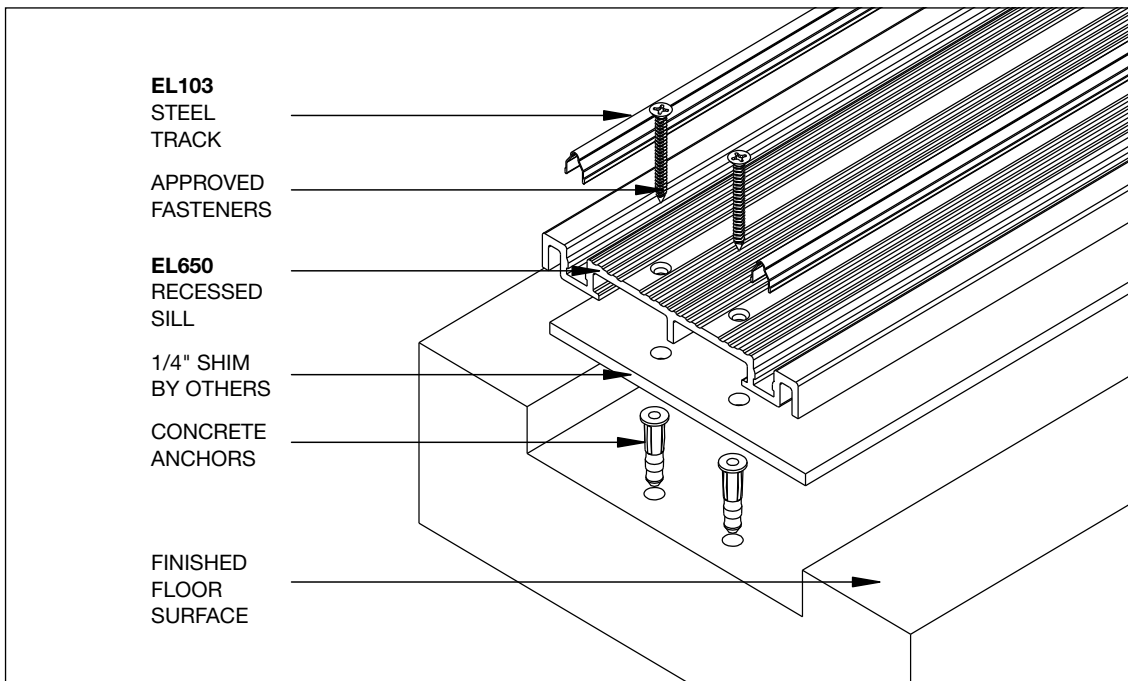
FIG. 5

**STEP 2 : INSTALLING THE RECESSED SILL (cont'd)**

6. Using shims, align the Recessed Sill again with the plumb bob and project the pre-drilled holes onto the bottom of the recessed slot using a sharp center punch or small pilot concrete drill (**FIG. 6**).
7. Remove Recessed Sill and complete the drilling for concrete anchors.
8. Install anchors, fasteners, shims, and Recessed Sill. It is critical that the Recessed Sill be flush to the surrounding floor surface. Adjustments to shims may be necessary as you secure the sill (**FIG. 7**).



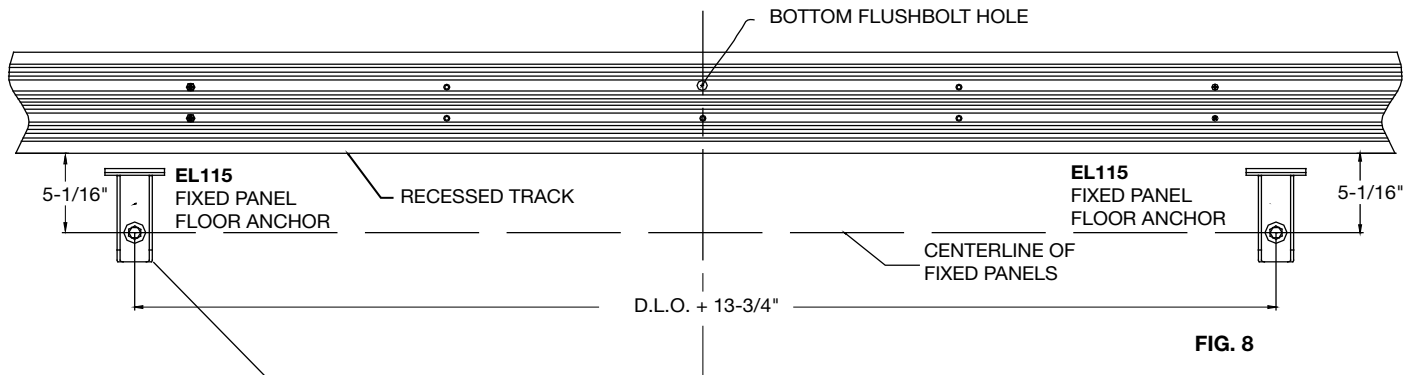
**FIG. 6**



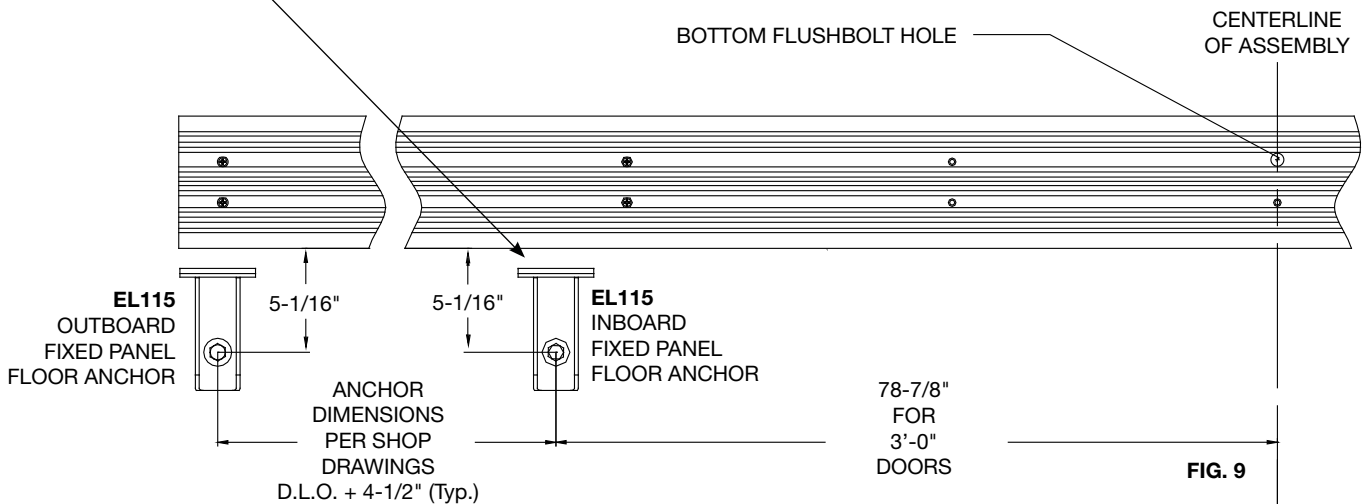
**FIG. 7**

**STEP 3 : MOUNTING THE WINDLOAD ANCHORS - FIXED PANELS**

1. Determine the sliding panel centerline from your Shop Drawings and mark the floor as illustrated below (FIG. 8).
2. For systems using two standard 3'-0" doors, the center-to-center measurement between mounting holes is 157-3/4" or 78-7/8" on each side of the sliding panel's centerline. On any door size, the correct centerline spacing for the EL115 Inboard Fixed Panel Floor Anchors are D.L.O. (Daylight Opening) + 13-3/4" (FIG. 8).



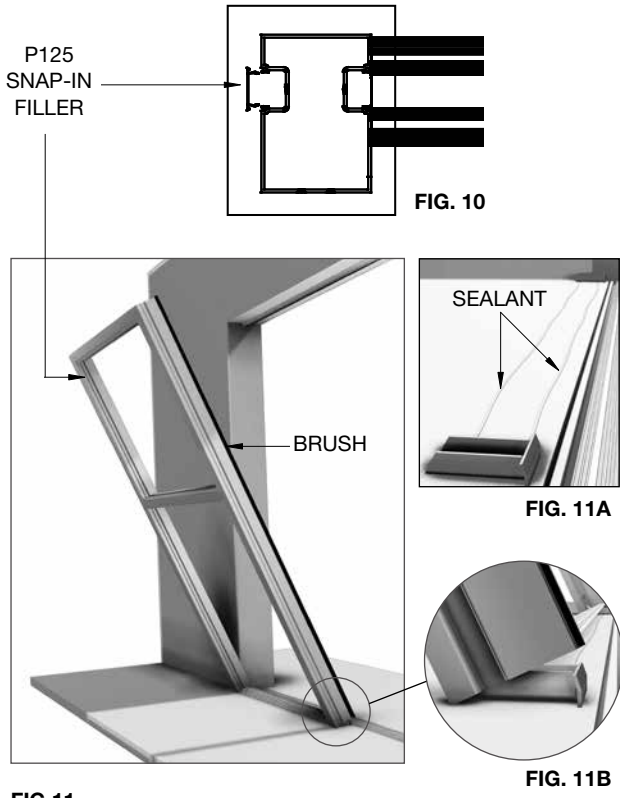
**FIG. 8**



**FIG. 9**

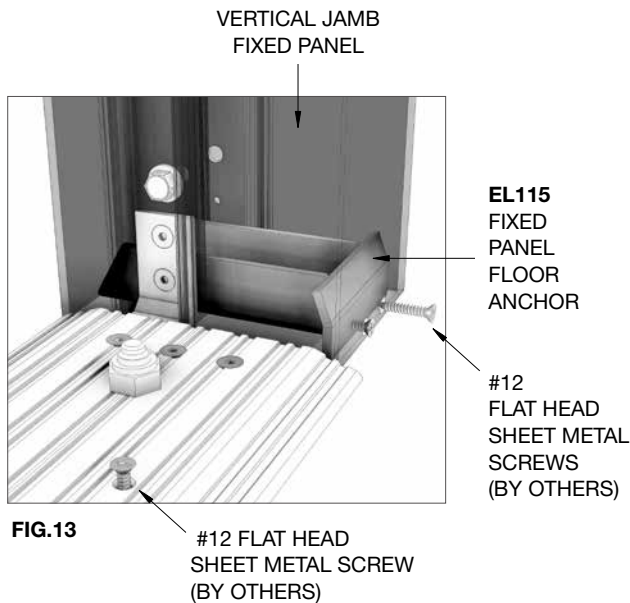
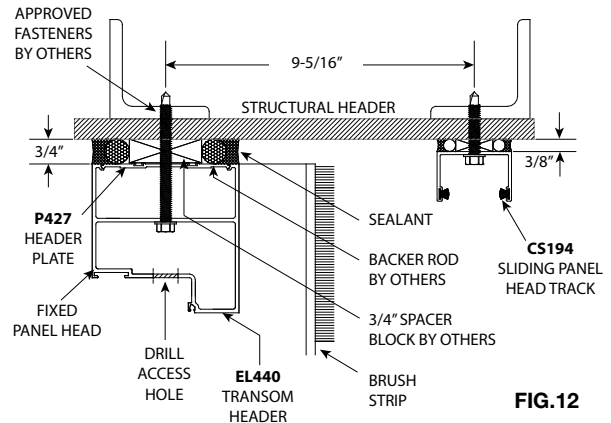
3. Install the Outboard EL115 Fixed Panel Floor Anchors as illustrated above. Refer to Job Site Drawings. Typically the spacing is D.L.O. (Daylight Opening) + 4-1/2" (FIG 9).

**STEP 4 : INSTALLING THE FIXED PANELS WITH THRESHOLD**



1. Insert the Snap-In Fillers on the outboard sides of the Fixed Panels per Shop Drawings (FIG 10).
2. Apply several beads of sealant to the floor surface between the Inboard and Outboard EL115 Floor Anchors prior to installing the Fixed Panels (FIG. 11A).
3. Position each Fixed Panel onto the EL115 Floor Anchors as illustrated (FIG. 11B). Be sure that the brush weatherstrip is towards the building's interior.
4. Stand the panel up vertically and align the center of the top rail 9-5/16" from the center of the sliding track. Check for plumb (FIG. 11).
5. Shim with a 3/4" spacer block. Drill access holes every 8" and insert fasteners into the Structural Header (FIG. 12). Refer to Shop Drawings.

**NOTE:** This method of attachment is only a recommendation. Local codes may specify something different. Refer to your Shop Drawings for the required hardware and attachment methods.



6. Drill and countersink #12 Flat Head Sheet Metal Screws through the Vertical Jamb of the Fixed Panels into the face of the EL115 Fixed Panel Floor Anchors (FIG. 13).
7. Secure the Fixed Panel Threshold to the floor surface with the specified fasteners.
8. Repeat the procedure for the other non-sliding panel(s).



**STEP 5 : INSTALLING THE FIXED PANELS WITHOUT SUBSILLS**

1. Refer to the Shop Drawings to determine if the installation requires the optional FF450 Subsills. If so, proceed to the next page.
2. If no Subsills are specified, mount each fixed panel directly to the flooring surface by fastening the base to the EL115 Fixed Panel Floor Anchors following the procedures in the previous Step 4 instructions (FIG. 14).



FIG. 14

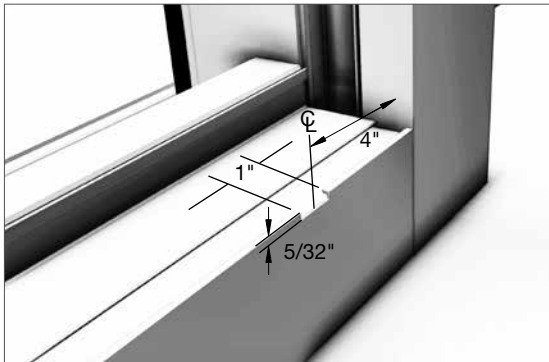


FIG. 15

3. Cut weep holes on the exterior side of the Base Sill, 4" from the frame to the center of the notch and 1" x 5/32" in size (FIG. 15).
4. Apply sealant to two sides of the glazing pocket and insert the WD200 Water Deflectors, sliding them down into position (FIG. 16).

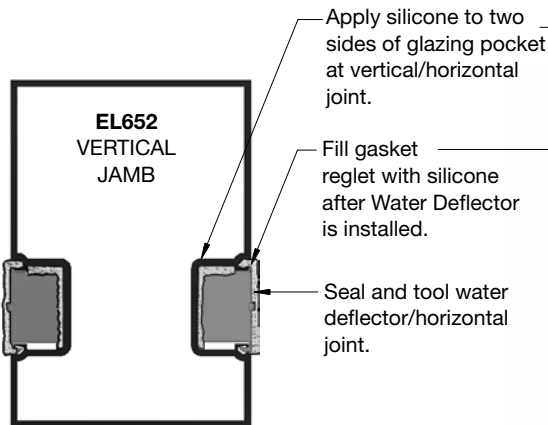


FIG. 16

Seal horizontal/vertical joint after Water Deflector is installed.

5. Seal the Upper Water Deflector on three sides. The front, unsealed gap will allow water to pass down to the Base Sill where it can exit through the Weep Holes (FIG. 16).
6. Seal the bottom Deflector on all sides (FIG. 17).
7. Finish by sealing all horizontal and vertical joints.

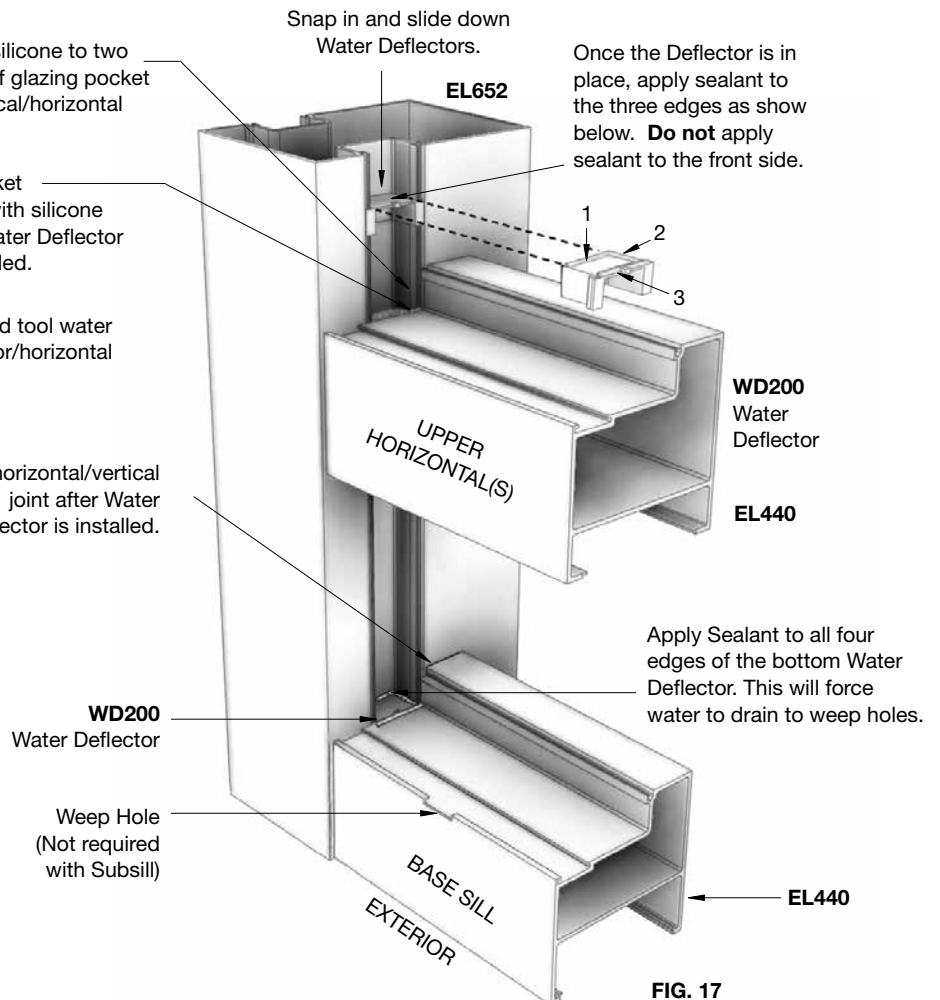


FIG. 17

**STEP 6 : INSTALLING FIXED PANELS WITH THE FF450 SUBSILL**

CRL-U.S. Aluminum recommends using the FF450 Subsills on all installations that require ground-level glazed panels. They are not required for fixed panels with doors and thresholds.

1. Cut the FF450 Subsill to the proper length and add Weep Slots. The slots are 1/2" wide on centers and 3/16" tall. The recommended placement is 4" from each Vertical Jamb and an 8" maximum separation (FIG. 18).

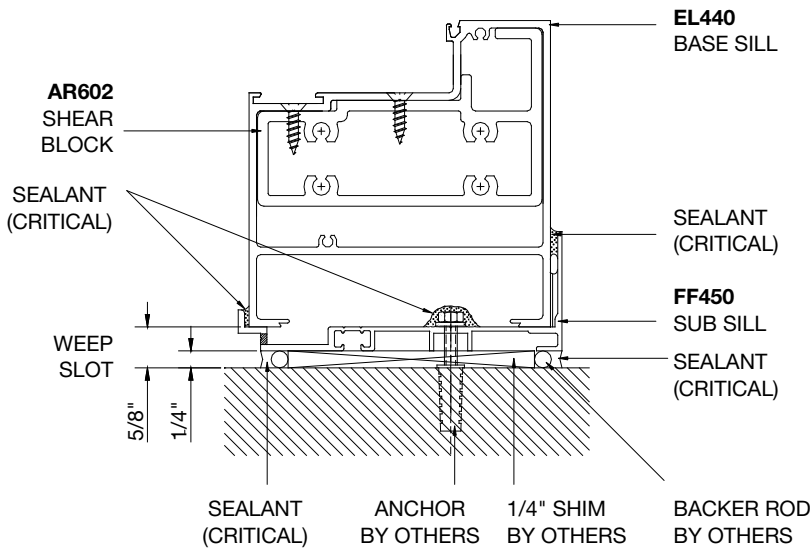


FIG. 19

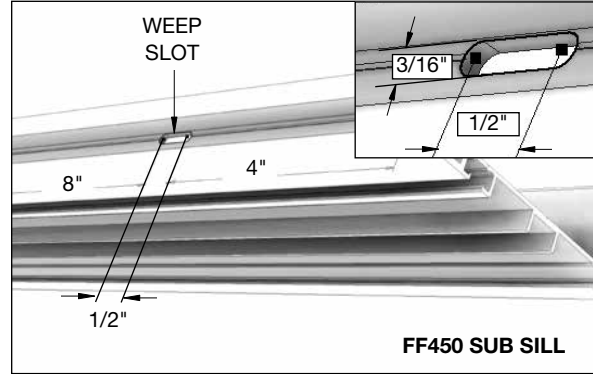


FIG. 18

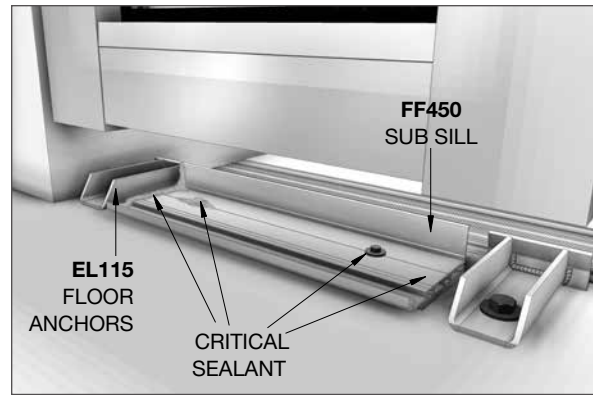


FIG. 20

2. Attach the Subsill on top of a 1/4" shim to the floor with the specified anchors (FIG. 18). Liberally apply sealant to each end of the FF450 Subsill and around all bolt heads (FIG. 19).
3. Place the Fixed Panel on top of the FF450 secured Subsill and the EL115 Fixed Panel Floor Anchors (FIG. 20). Follow the upper head mounting procedures in Step 4 Section 4-6 (FIG. 12).
4. Carefully apply sealant to the Base Components. Do not block the Weep Slots (FIG. 21).

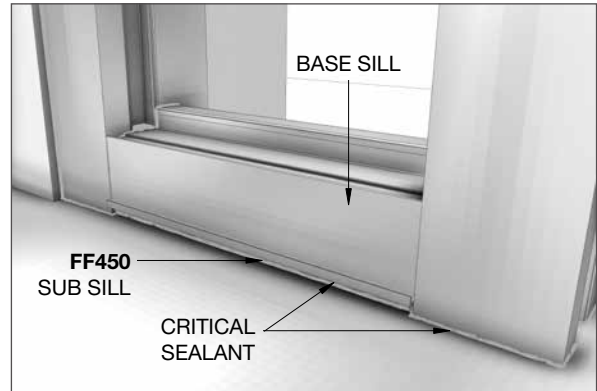
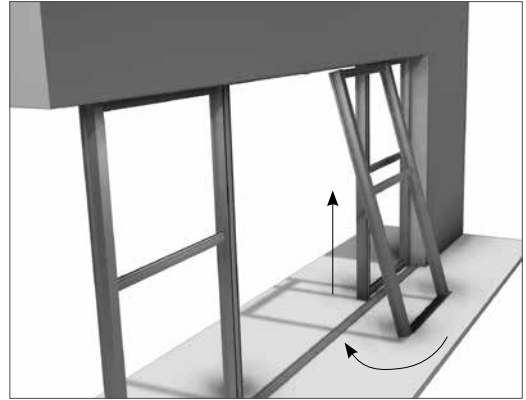


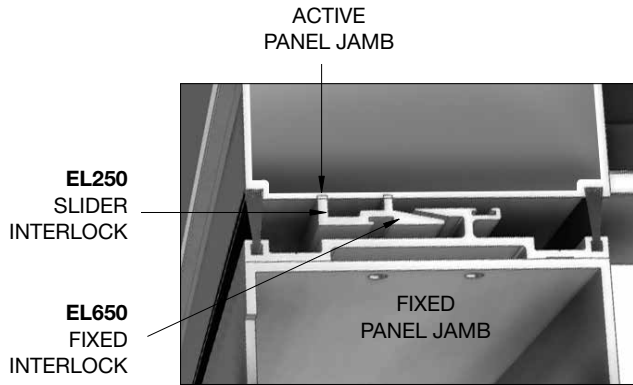
FIG. 21

**STEP 7 : INSTALLING THE SLIDING PANELS**

1. Determine the correct orientation for the Sliding Panels from the Shop Drawings.
2. Standing to the interior, insert the top of the panel into the CS194 Head Track then swing the bottom rollers onto the rails of the Recessed Sill (**FIG. 22**).
3. Be sure that the doors engage the jamb interlocks after standing the panels (**FIG. 23**).



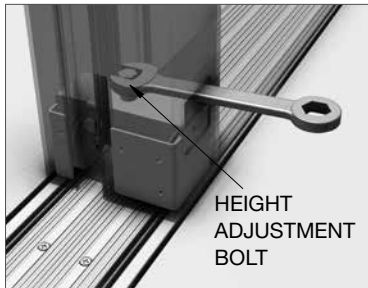
**FIG.22**



**FIG. 23**

**TOP VIEW**

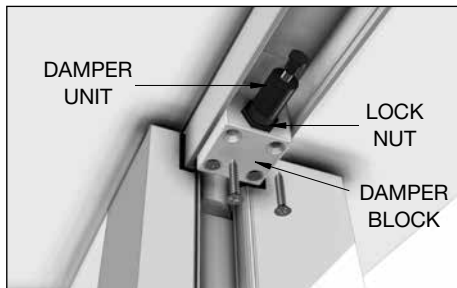
4. Roll each sliding panel back-and-forth a few times to make sure that it is seated properly on the track.
5. Close the inactive sliding panel and engage the upper and lower flush bolts. Next, close the active panel and assure that the cylinder lock engages.
6. Minor alignment changes may be made to the active panel by removing the access plate at the bottom of the inboard vertical jamb and turning the Height Adjustment Bolt (**FIG. 24**).



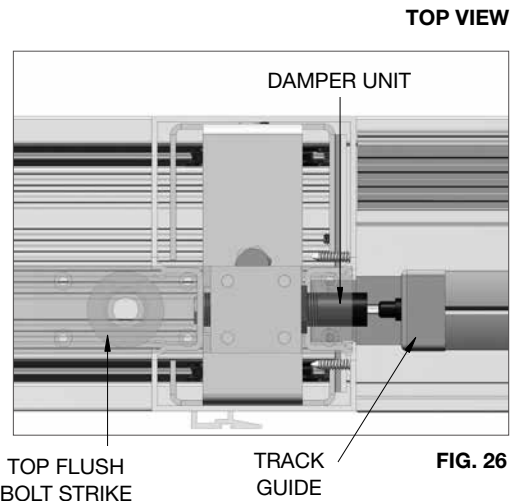
TO RAISE -  
TURN CLOCKWISE

TO LOWER -  
TURN COUNTER-CLOCKWISE

**FIG.24**



**FIG. 25**

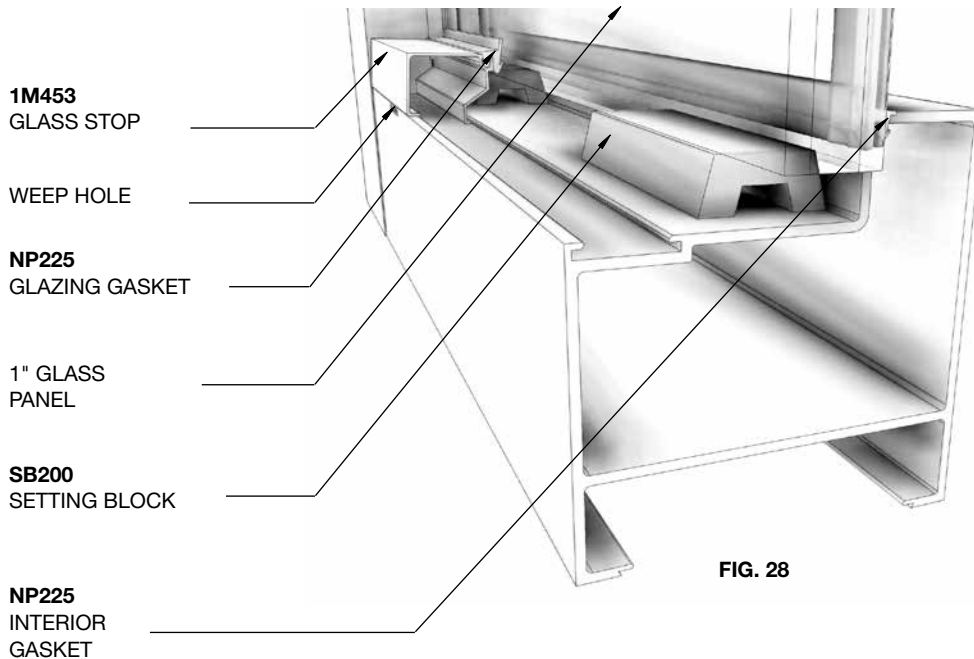
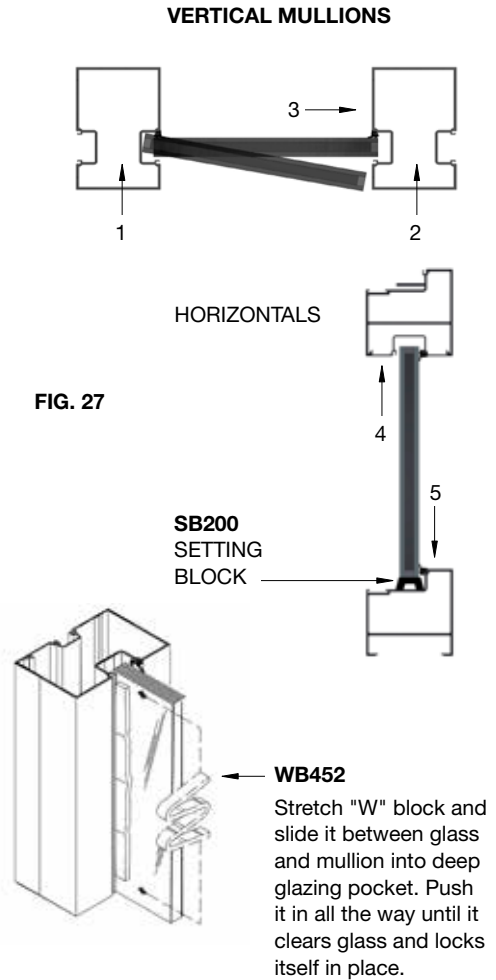


**FIG. 26**

7. Slide the Active panel open and re-attach the Damper Block (**FIG. 25**). Turn the Damper Unit until it touches the end of the track guide on the top of the inactive panel and tighten the lock nut (**FIG. 26**).

**STEP 8 : EXTERIOR GLAZING**

1. Cut glazing gaskets to size. Gaskets should be 1/8" longer per foot of aluminum member to allow for shrinkage. The same gaskets are used at the interior and exterior.
2. Install interior gasket. Vertical gasket runs through. Start at corners and work towards center. Tight butt-joined corners are critical to avoid leakage. Seal ends of horizontal gaskets prior to abutting to vertical gaskets.
3. Set glass in place following the four step procedure. Be careful not to disturb interior gasket while installing glass. Center glass in the opening (**FIG. 27**).
4. Locate setting blocks in horizontal/sill member. Unless otherwise noted on the Shop Drawings, all setting blocks will be at quarter points. Rest glass on setting blocks pressed against installed gaskets.
5. To prevent glass from shifting in the opening, one "W" Side Block should be installed into each deep glass pocket of the vertical at center point or as recommended by glass manufacturer. Side blocking is recommended to prevent glass from shifting in the pocket.
6. Snap in the 1M453 Glass Stops and the remaining NP225 Exterior Glazing Gaskets.



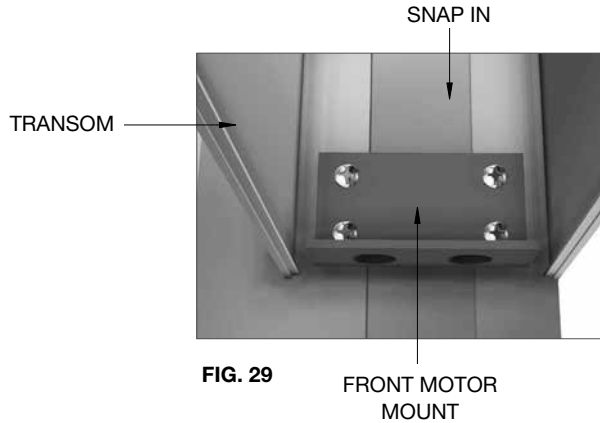
**STEP 9 : OPTIONAL POWER OPERATED DOORS**

If your project requires power operated doors, the following items will be included with the order per door:

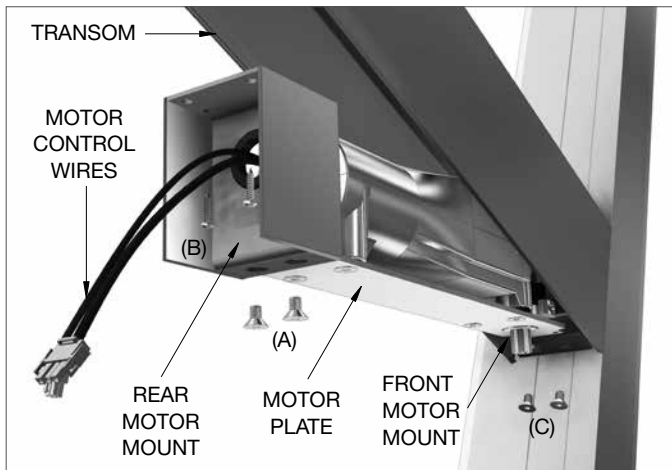
- (1) Stanley Magic Force Swing Door Operator
- (1) Stanley Magic Force Dual Controller
- (1) Stanley Magic Force Concealed Door Arm
- (1) Set of internal electrical connection hardware.

The installer is responsible for all external power supply hardware to the door system (See site prep section).

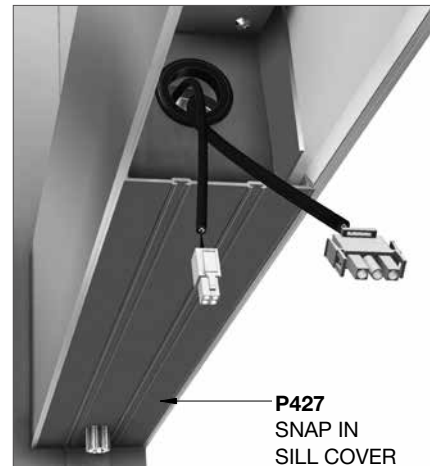
1. Install the "Snap-in" Covers on both sides of the opening before proceeding (**FIG. 29**).
2. Attach the Front Motor Mount to the Vertical Jamb (**FIG. 29**).



**FIG. 29**



**FIG. 30**



**FIG. 31**

3. Feed the motor control wires through the grommet on the Rear Motor Mount and attach it to the Stanley Motor Plate using (2) 5/8 -16 X 5/8" flat head screws (A) (**FIG. 30**).

Lift the front of the Motor Plate up into the Transom and set it onto the Front Motor Mount. Lift the rear of the assembly up and attach it to the Transom with (2) 1/4-20 x 1" hex head bolts (B) while inserting the Front Motor Mount using (2) 5/8 -16 X 5/8" flat head screws (C) (**FIG. 30**).

4. Attach the bottom, Snap In Sill Cover and repeat the procedure for the opposite side (**FIG. 31**).

## STEP 9 : OPTIONAL POWER OPERATED DOORS (Cont'd)

5. Remove the end cap at the top of the door.
6. Detach the Motor Arm from the door top by removing the (4) 1/4"-20 X 1" Hex Bolts. Do not remove the shim plate below the arm.
7. Slide the motor arm onto the protruding splined motor drive shaft but **Do Not** tighten the set screw on the end at this point (**FIG. 32**).
8. Set the bottom pivot receiver onto the threshold pivot pin (**FIG. 33**).
9. Manually rotate the Motor Arm as you swing the top of the door upward. Align the four screw holes in the Motor Arm, Motor Arm Shim and door top. Insert the (4) 1/4"-20 X 1" Hex Bolts and tighten (**FIG. 34**).
10. Tighten the set screw and attach the End Cap.

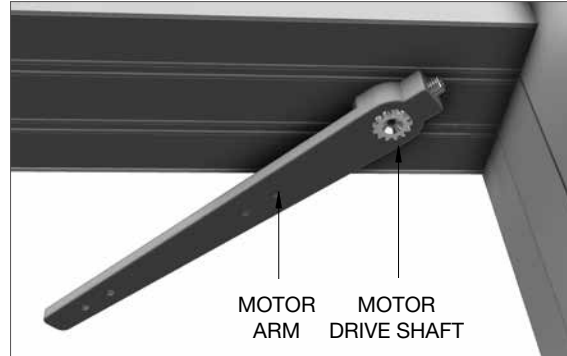


FIG. 32

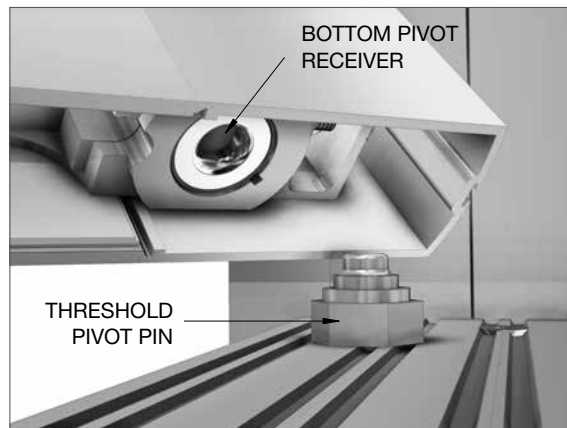


FIG. 33

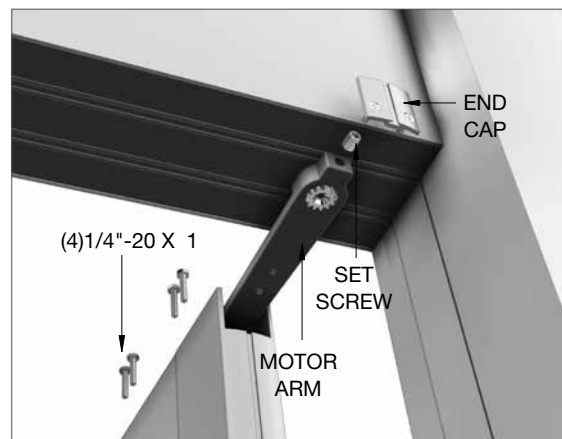


FIG. 34

