

# SHORIZON®

## CUTTING FORMULA FOR CHATEAU SERIES SLIDING DOOR KITS

### Components Description

HEADER  
SIDE JAMB  
BOTTOM TRACK  
TOWEL BAR  
TOWEL BAR  
KNOB  
HARDWARE (Including Guide)

### Metal Size Cutting Formula

HEADER = Top Width Measurement Less 1/16" (1.5 mm)  
SIDE JAMB = Overall Height Less 1-1/2" (38 mm)  
BOTTOM TRACK FOR EK SERIES = Bottom Width  
Measurement Less 3/4" (19 mm)

### Glass Size Cutting Formula

WIDTH FOR EK SERIES = Overall Width Divided By 2 Plus 3/8" (10 mm)  
HEIGHT FOR EK SERIES = Overall Height Less 2-5/8" (67 mm)

### All Stock Chateau Sliders Come with a Knob and a 24" (610 mm) Towel Bar

Towel Bar and Knob require 1/2" (12 mm) diameter holes.

Holes for Towel Bar should be 24" (610 mm) center-to-center.  
The recommendation is to center the Towel Bar both vertically  
and horizontally on the glass.

Placement of the Knob should be such that it is in line  
horizontally with the Towel Bar. The hole should be  
centered 3" in from the edge of the glass.

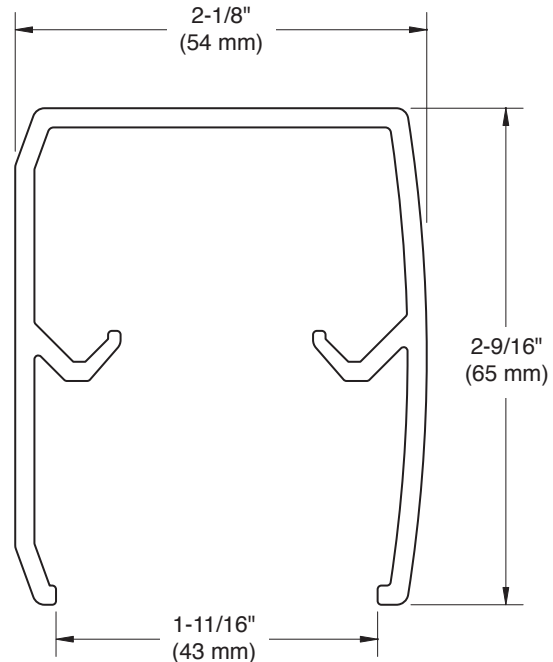

Header

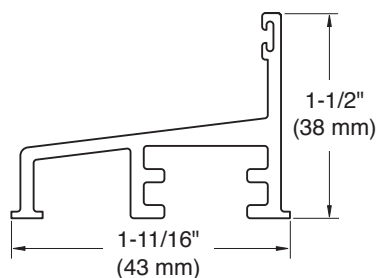

Bottom Track

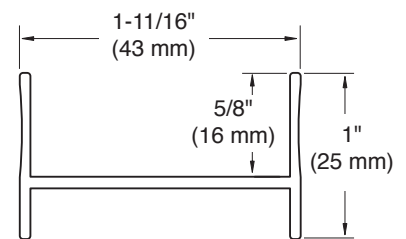

Side Jamb

Note: Drawings not to scale.

**US HORIZON**

[ushorizon.com](http://ushorizon.com)

28577 Industry Drive, Valencia, CA 91355

Toll Free Phone: (877) 728-3874

Toll Free Fax: (888) 440-9567

Phone: (661) 775-1675

Fax: (661) 775-1676

# SHORIZON®

## THIS INFORMATION APPLIES TO CHATEAU SERIES SLIDERS

### Assembly Instructions for EK Series Sliders:

1. Clean the top edge of the glass to fasten the Roller Brackets.
2. Place the Roller Brackets approximately 2" (51 mm) in from the vertical edge of the glass to the edge of the Bracket. There is no adhesive required.
3. Place the loose clamping plate between the Allen head set screws and the glass.
4. Tighten the Roller Brackets with the T-handle Allen wrench provided, until the wrench twists a quarter turn.

### Installation Instructions for EK Series Sliders:

1. Place the Bottom Track in the desired position on the tub/curb. Use a level to plumb your Side Jamb. Mark the holes for drilling.
2. Drill the holes into the vertical walls. Use the appropriate anchors to prepare for fastening Side Jamb.
3. Run a bead of Clear Silicone to the underside of the Bottom Track. Immediately put the Track into position.
4. Fasten the Side Jamb into the vertical walls using the screws provided. Be sure to clean up any excess silicone at this time.
5. Install the Header and fasten it to the Side Jamb on the inside.
6. Hang the panels (the inside panel is hung first). Make the necessary adjustments to accommodate for out-of-level/plumb conditions.
7. Attach the Single-Sided Knob to the inside panel and Single-Sided Towel Bar to the outside panel.
8. Run a bead of of Clear Silicone at each end of the Bottom Track where it meets the Jamb.
9. Allow 24 hours for the Silicone to cure prior to using the enclosure.

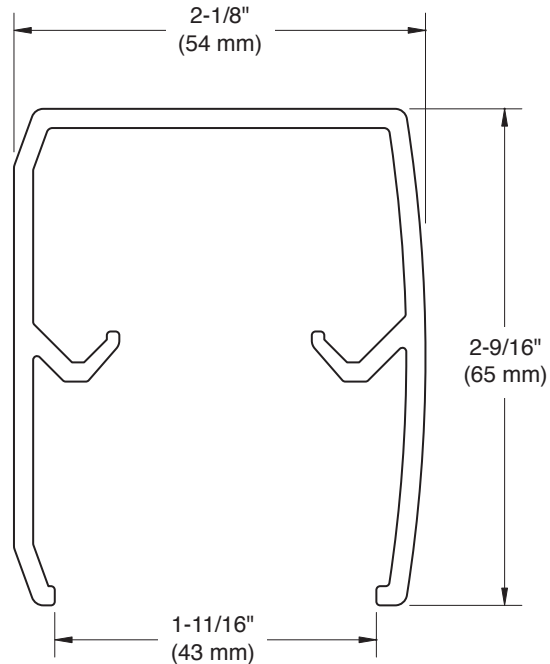

Header

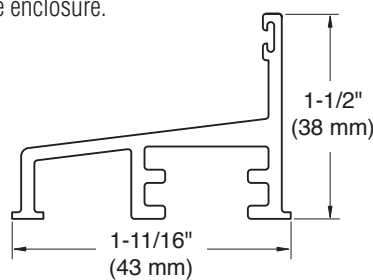

Bottom Track

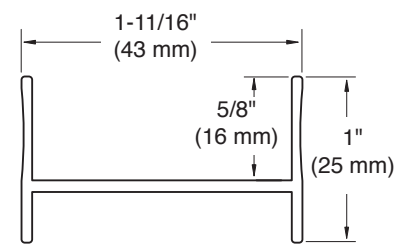

Side Jamb

Note: Drawings not to scale.

**US HORIZON**

[ushorizon.com](http://ushorizon.com)

28577 Industry Drive, Valencia, CA 91355

Toll Free Phone: (877) 728-3874

Toll Free Fax: (888) 440-9567

Phone: (661) 775-1675

Fax: (661) 775-1676