

# INSTALLATION INSTRUCTIONS

## Aluminum Railing System

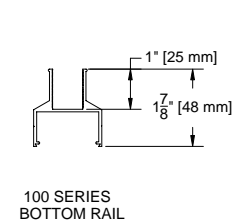
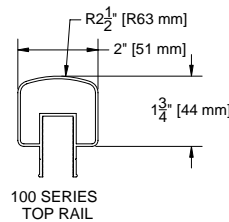
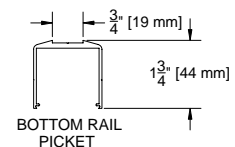
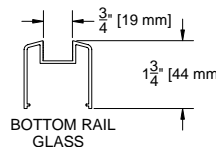
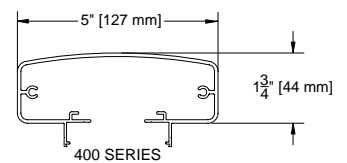
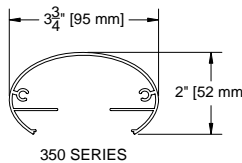
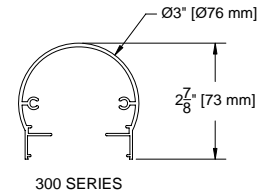
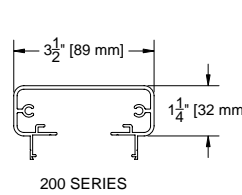
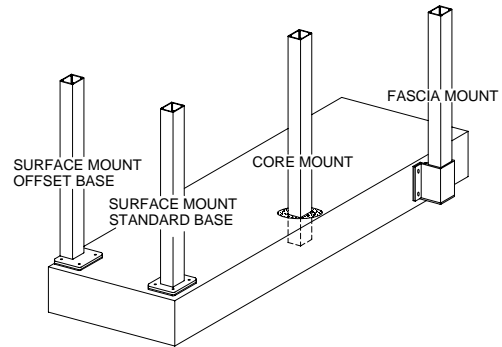
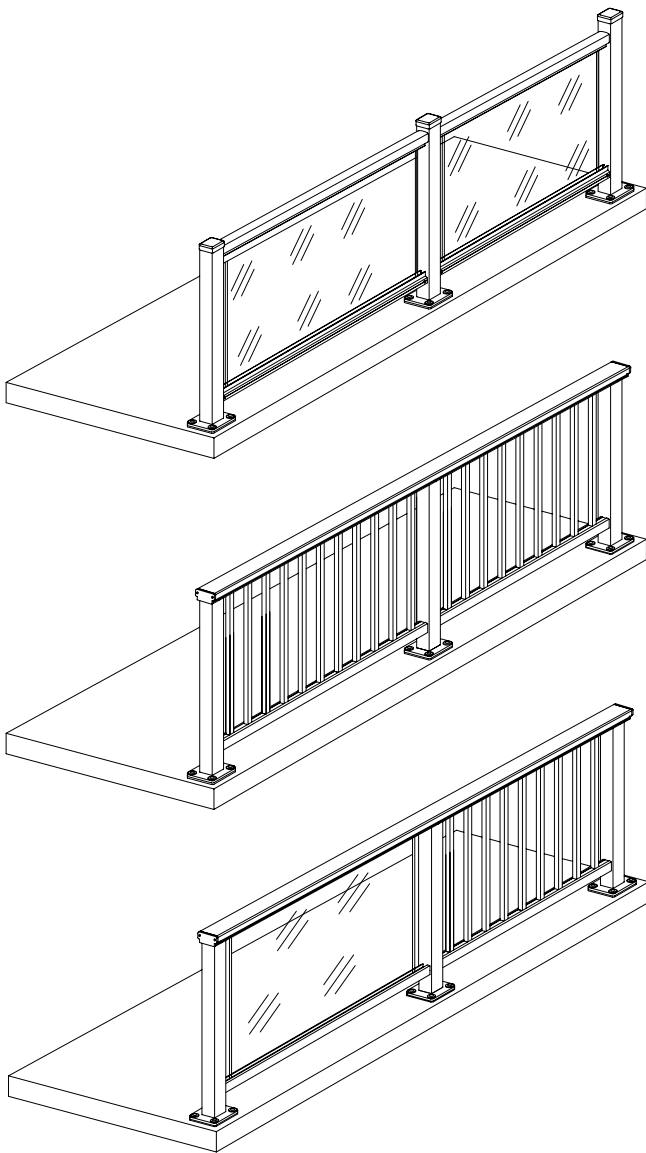

**Vertical Post Kits:**

C.R. Laurence Co., Inc. offers various types of mountings for securing Posts.

**Surface mount (Standard Base).**

This is the most popular type of mounting. The Post is connected to a 5" (127 mm) square base, which is mounted to the floor.

**Surface mount (Offset Base)**

The Post is offset on the base to allow the post to be flush against a wall or aligned with a vertical face.

**Fascia Mount**

This mount allows the Post to be mounted to the vertical face of a wall or slab.

**Core Mount**

This method of mounting requires coring a hole in the floor, installing the Post and filling the hole with "Kwixset" Cat. No. KWK50 Cement.

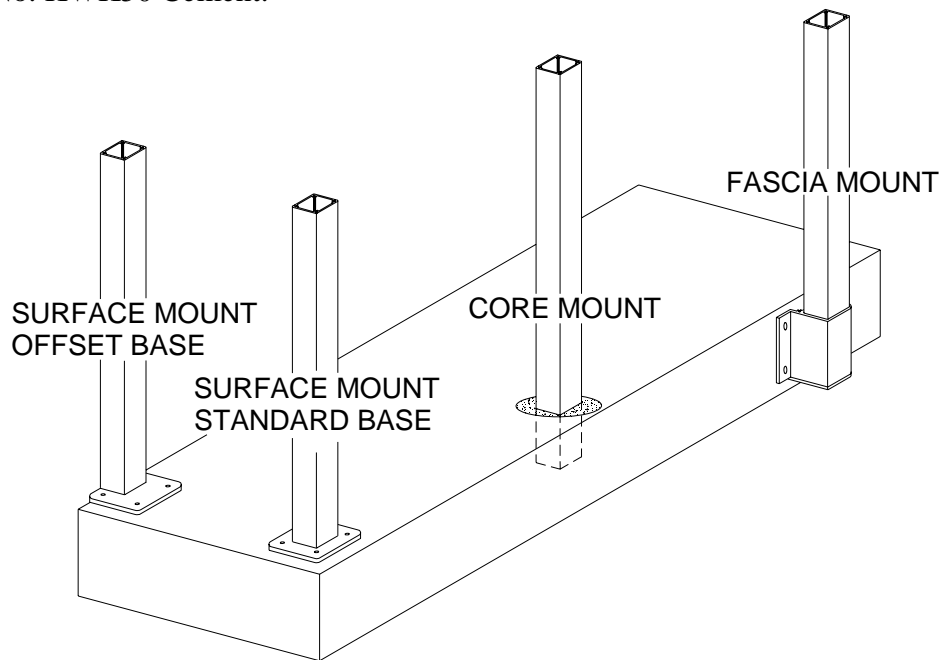

**Post assembly and installation**

**Surface mounted Posts.** Assemble the Base Plate to the Post with the 1/4" (6 mm) x 1-1/2" (38 mm) Cat. No. BPS112 screws provided. Position the included Moisture Barrier Gasket between the substrate and the base plate prior to mounting. *Helpful Hints: Lubricate the screws and assembly will be much easier.*

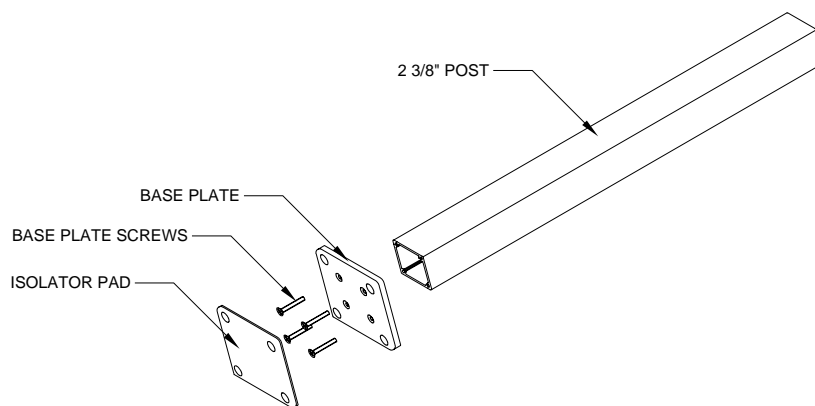

When installing Posts, start with the outside or corner Posts first. Make sure they are plumb and level then install the intermediate Posts. *Helpful Hints: Make sure you put the special cup washer under the bolt before driving it in. This washer is used to secure the bolt cover button.*

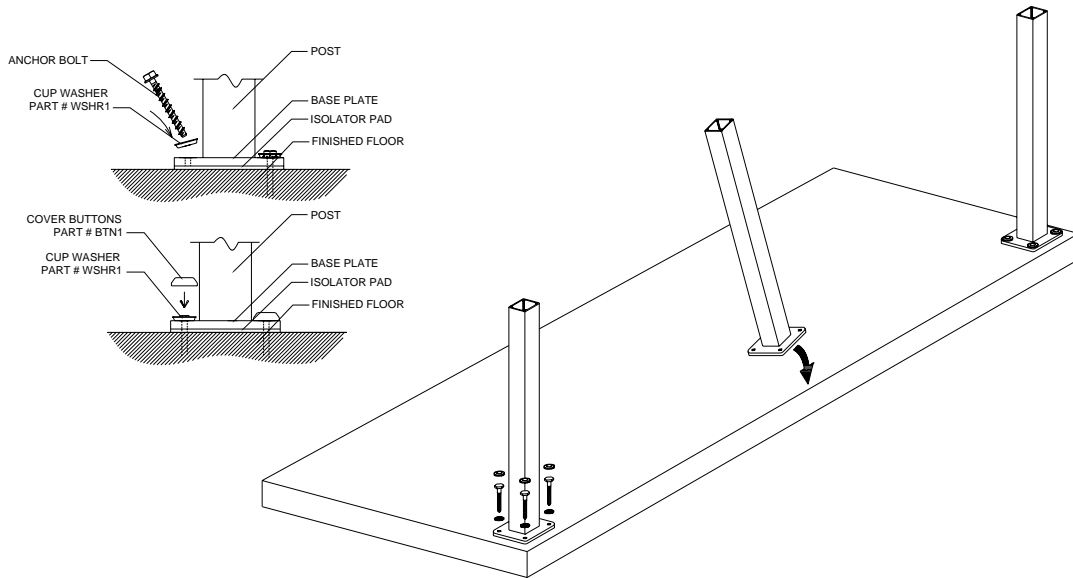

**Fascia Mounted Posts.** Place Moisture Barrier Gaskets to the Fascia Brackets. Attach the Fascia Brackets to the fascia. Start with the outside or corner Brackets first, then install the intermediate Brackets. Once the Bracket is secured, screw the Base Plate onto the Bracket. Then lower the Post into the Bracket and secure it to the Base Plate with screws provided. *Helpful Hints: Lubricate the screws and assembly will be much easier.*

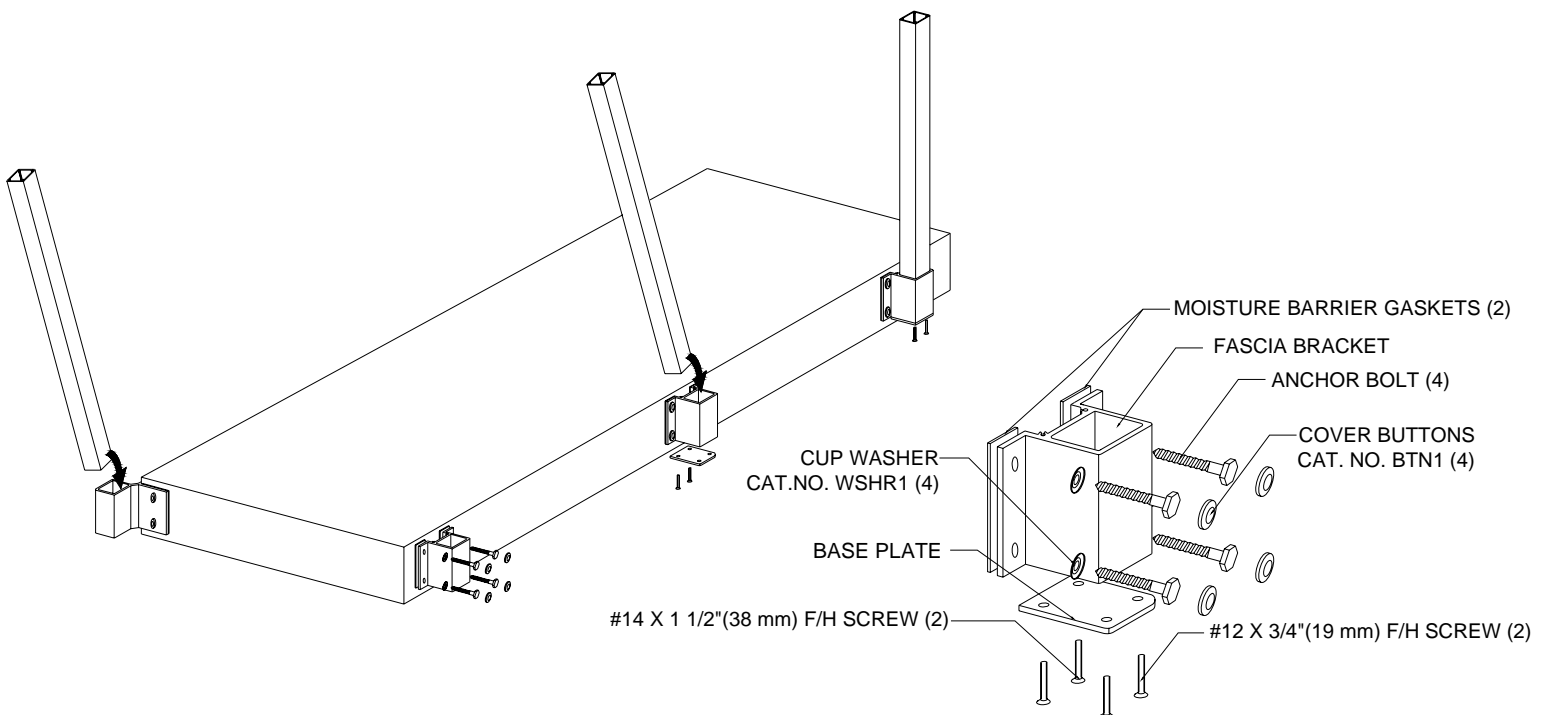

**Core Mounted Posts:** Core hole a minimum of 4" (102 mm) Diameter X 6" (152 mm) deep. Install the Post. Secure Post plumb and level, then fill cavity with "Kwixset" Cat. No. KWX50 Cement. Start with the outside or corner Posts. Then install the intermediate Posts.

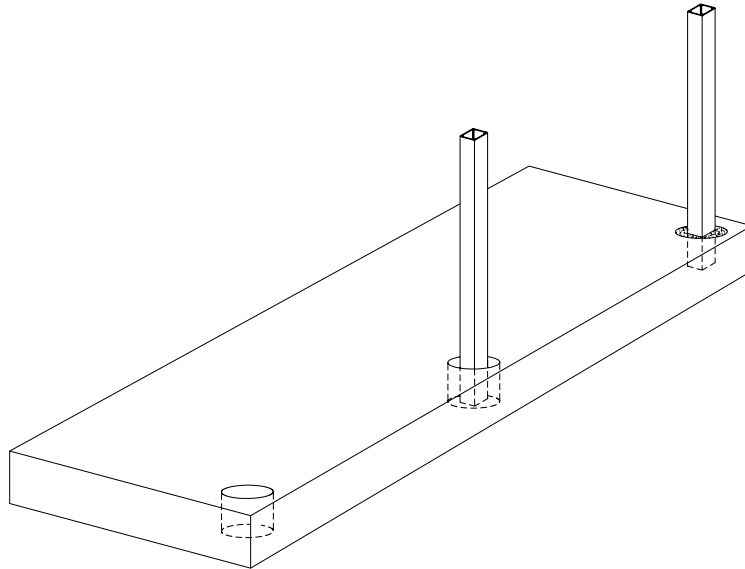

**Top Caps**

C.R. Laurence has a number of Top Caps available offering a selection of appearances and applications.

**100 Series** offers a rectangular section rail with a crowned top, which runs between posts. This Top cap is the only one used for stairways and conforms to UBC requirements.

**200 Series** is a rectangular section Rail that runs continuously across the top of the Posts.

**300 Series** is a round section Rail that runs continuously across the top of the Posts.

**350 Series** is an oval section Rail that runs continuously across the top of the Posts.

**400 Series** is a rectangular section Rail with crowned top, which runs continuously across the top of the Posts.

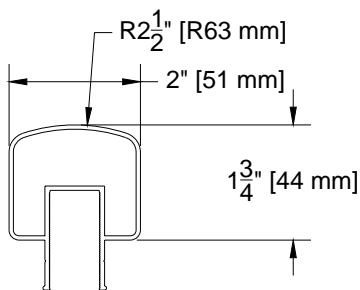

100 SERIES  
TOP RAIL

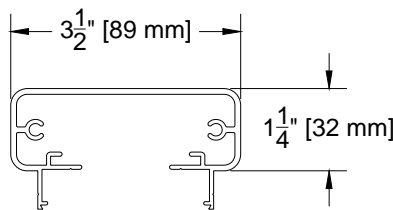

200 SERIES

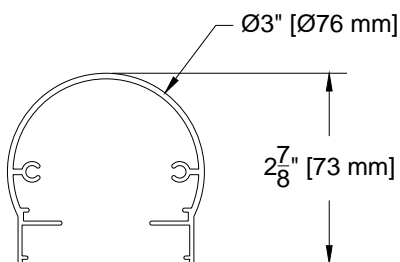

300 SERIES

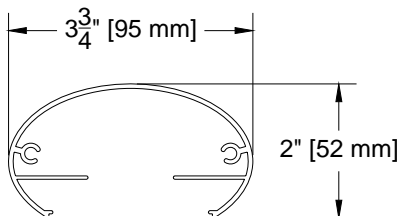

350 SERIES

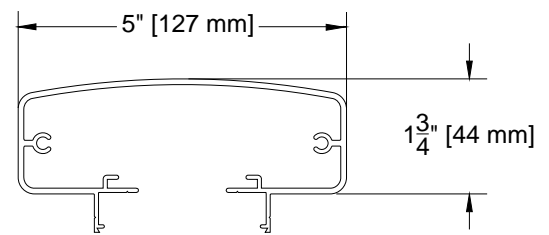

400 SERIES

## 100 Series Installation Instructions

### 100 Series Top Cap Installation:

Attach the 100 series Top Connector Block Cat. No. RCB1 to the sides of the Posts. Typically the distance from the top of the Post to the first hole is 2-1/4" (57 mm) and 3-1/4" (83 mm) to the lower hole.

*Helpful Hints: Use the die lines in the Post extrusion as a guide for the holes. This will ensure the Connector Block is centered on the Post.*

Cut the Top Cap to length. Slide the Top Cap over the Connector Blocks and secure with self-drilling Tek Screws Cat. No. TEK1. *Helpful Hints: Use the die line on the bottom leg of the Top Cap extrusion as a guide for the screws. Screws should be approx. 1/2" (12 mm) from the edge of the Post.*

Secure the post caps to the top of the posts using silicone adhesive Cat. No. 95C.

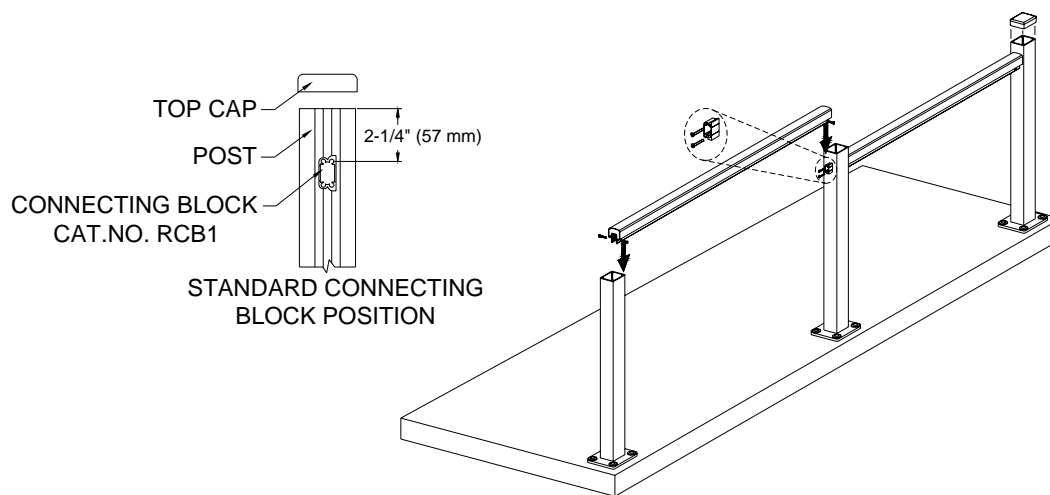

### 100 Series Bottom Rail Installation

Attach the 100 series Connector Block Cat. No. RCB1 to the sides of the Posts. Typically the distance from the floor to the bottom of the rail is 3" (76 mm). This will give a dimension of 3-3/8" (86 mm) from the floor to the center of the lower holes in the block. *Helpful Hints: Use the Die lines in the Post extrusion as a guide for the holes. This will ensure the Connector Block is centered on the Post.*

Cut the Bottom Rail to length. Slide the Rail over the Connector Blocks and secure with self-drilling Tek Screws Cat. No. TEK1. *Helpful Hints: Use the die line on the bottom leg of the Bottom Rail extrusion as a guide for the Screws. Screws should be approx. 1/2" (12 mm) from the edge of the Post.*

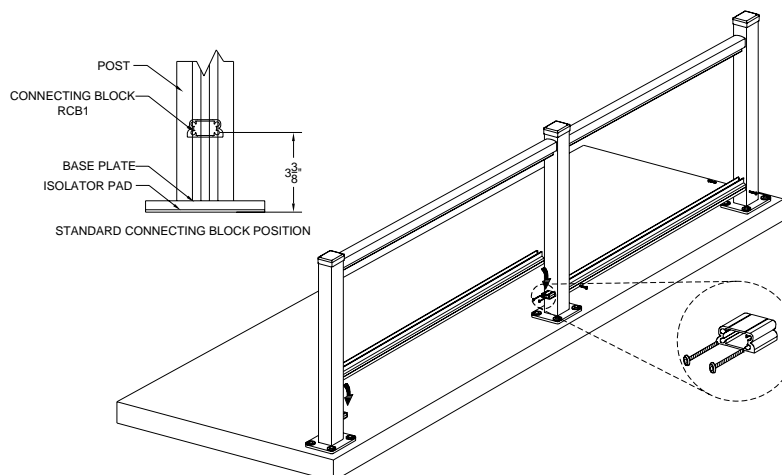

### **100 Series Glass Installation**

Install two Spacer Blocks into Bottom Rail. One at each end, 3" (76 mm) from edge of Post.

Cut vinyl the same length as the Rails. Push fit into the Rails.

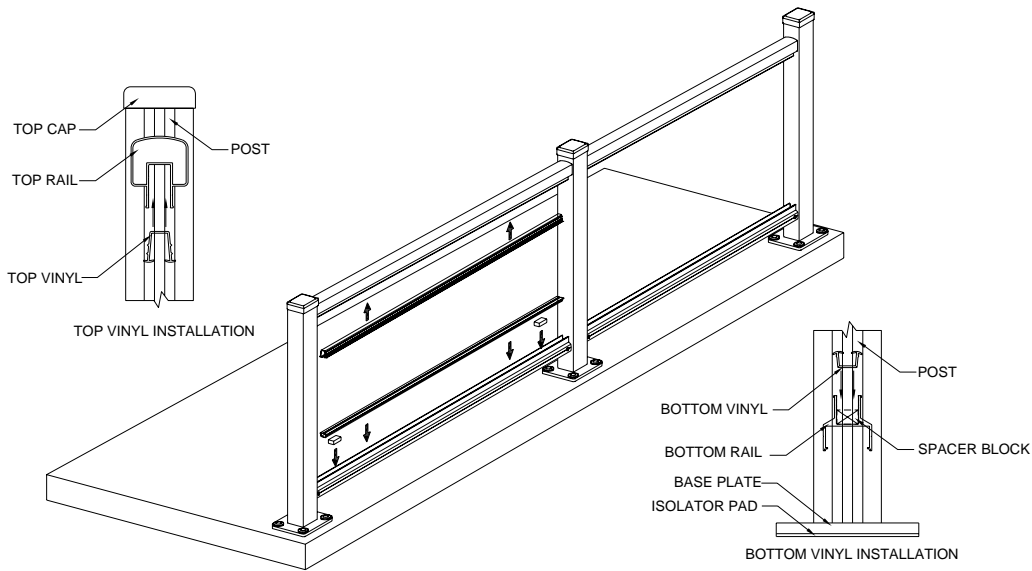

Glass size is determined by the daylight opening.

**Height:** Daylight Opening plus 3/4" (19 mm).

**Width:** Daylight Opening minus 3" (76 mm). (1-1/2" [38 mm] each side).

To install glass, insert fully into the Top Vinyl, then align the bottom edge with the Bottom Vinyl and press the glass down into the Vinyl.

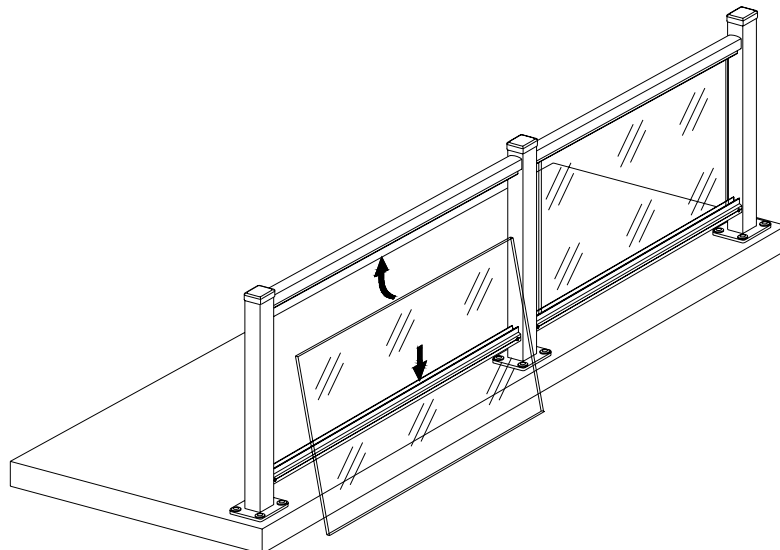

**100 Series Picket Installation:**

Install Picket Vinyl into the Top and Bottom Rails.

Snap fit one Picket Spacer onto Top and Bottom Rails adjacent to the Post.

Cut Pickets to length using: Daylight opening Plus 1-1/2" (38 mm).

Install picket, then snap fit next set of spacers, and continue on.

*Helpful Hints: Install the last few Pickets together before snap fitting the Spacers.*

*Then fit the Spacers evenly between the Pickets. Trim the last set of Spacers to fit the remaining gap.*

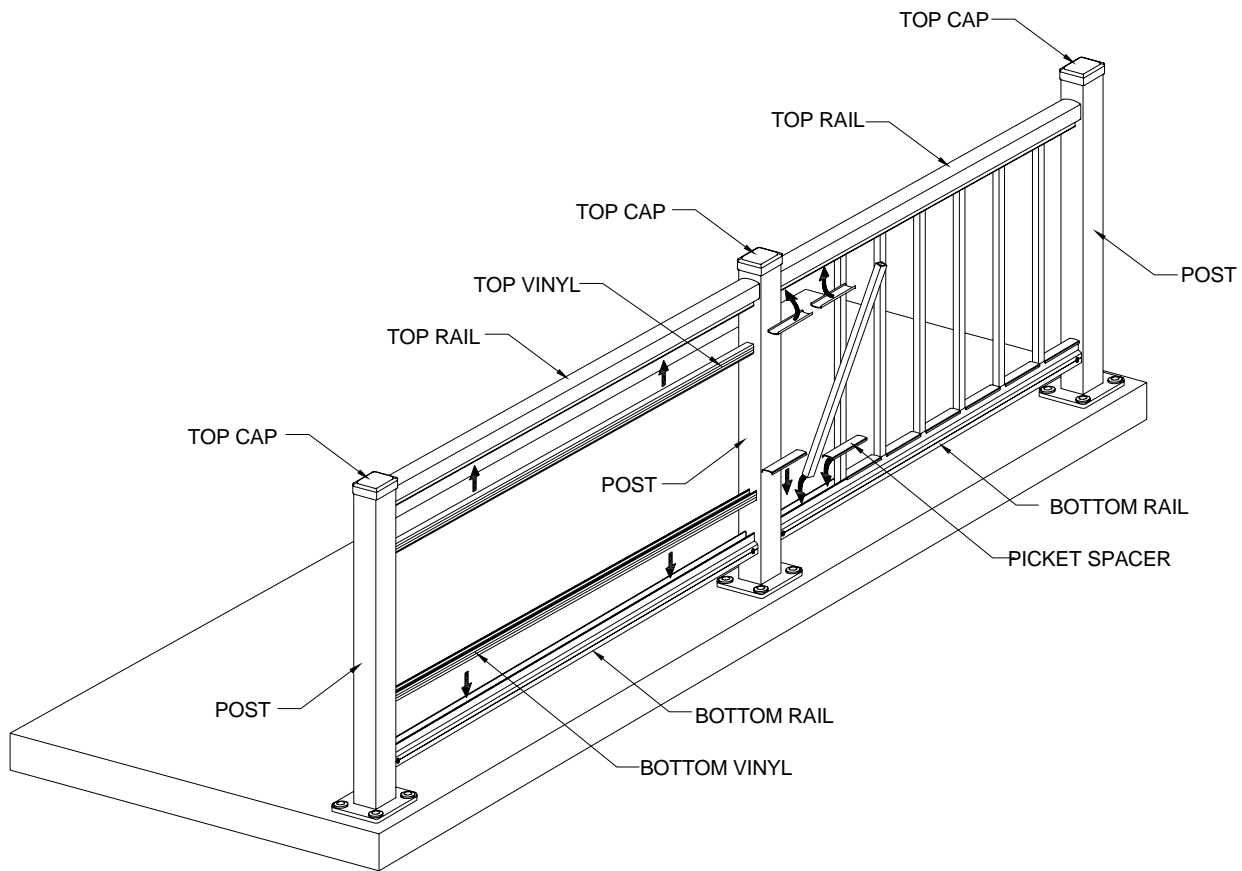

## **200, 300, & 400 Series Installation Instructions**

### **200, 300, & 400 Series Top Cap Installation:**

Illustrations are of the 200 Series. 300, & 400 Series follow the same procedures.

Cut Top Cap to length. Locate Top Cap onto Posts and secure with self-drilling Tek Screws Cat. No. TEK1. Install End Caps with Flat Head Screws Cat. No. ECS1. *Helpful Hints: Use the die line on the bottom leg of the Top Cap extrusion as a guide for the screws. Screws should be centered over the Post.*

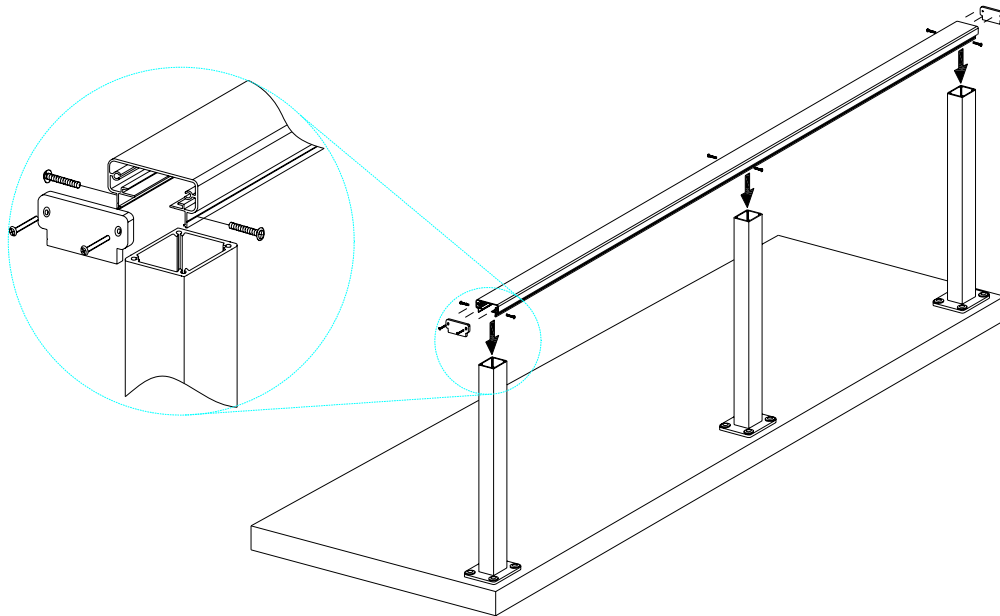

### **200, 300, 350 & 400 Series Rail Connecting Block Installation:**

Install the Rail Connector Blocks onto the Posts using the self-drilling screws provided.

The Rail Connector Blocks (Cat. No. RCB2) are used to support the Bottom Rails. Typically the distance from the floor to the bottom of the rail is 3" (76 mm). This will require the holes for the Rail Connector Blocks to be 4-3/8" (111 mm) up from the floor. *Helpful Hints: Use the Die Lines in the Post extrusion as a guide for the holes. This will ensure the Rail Connector Block is centered on the post. Height of the holes is dependent on the height of the Bottom Rail from the floor.*

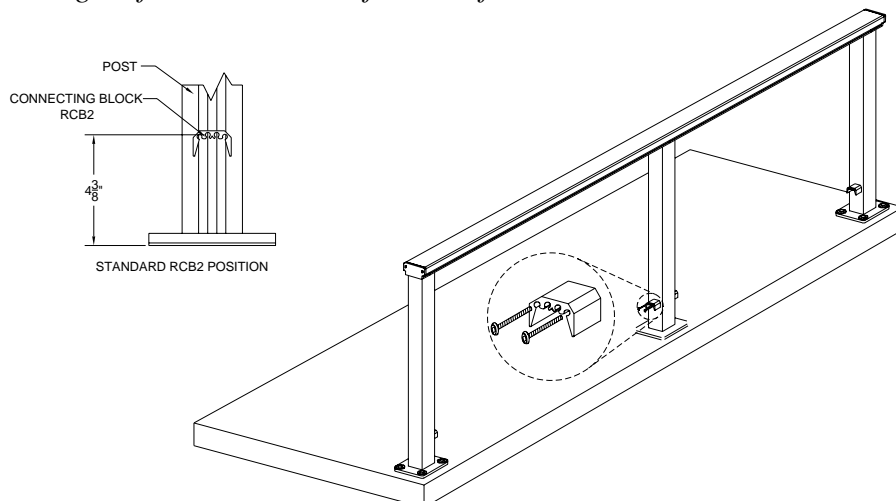

**350 Series Top Cap Installation:**

Secure the 350 Series Post Top Adjustable Brackets Cat. No. CB350L and CB350R to the top of the Posts using the #14 x 3/4" (19 mm) Screw Cat. No. CBS1. Two right-sided Brackets or two left-sided Brackets are needed for center 180° degree Posts, and a left-sided Bracket and a right-sided Bracket is needed for Corner 90° Degree Posts. Cut Top Cap to length. Locate Top Cap onto Adjustable Brackets and secure from under Top Rail with self-drilling Tek Screws Cat. No. TEK1.

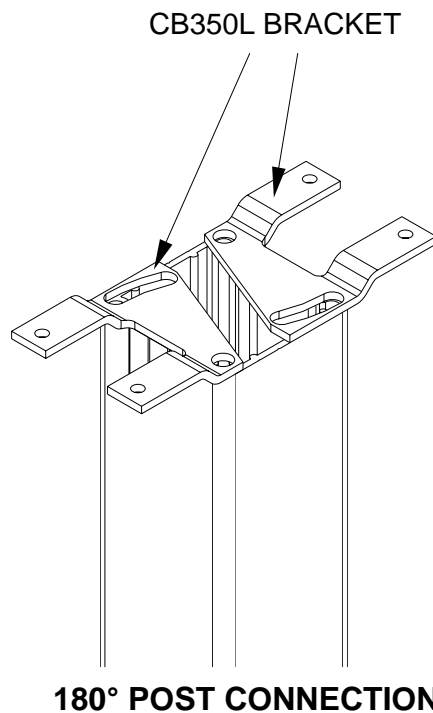
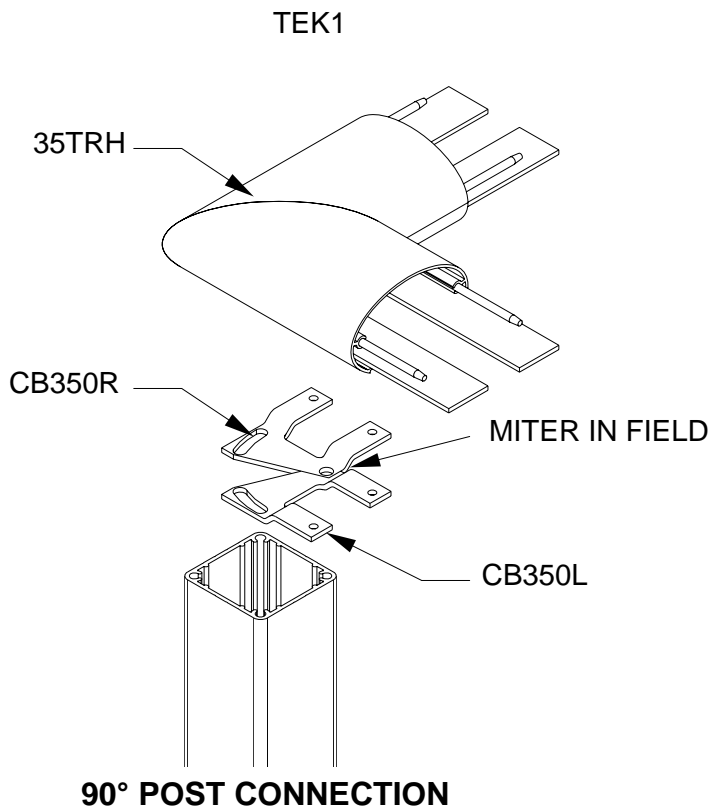
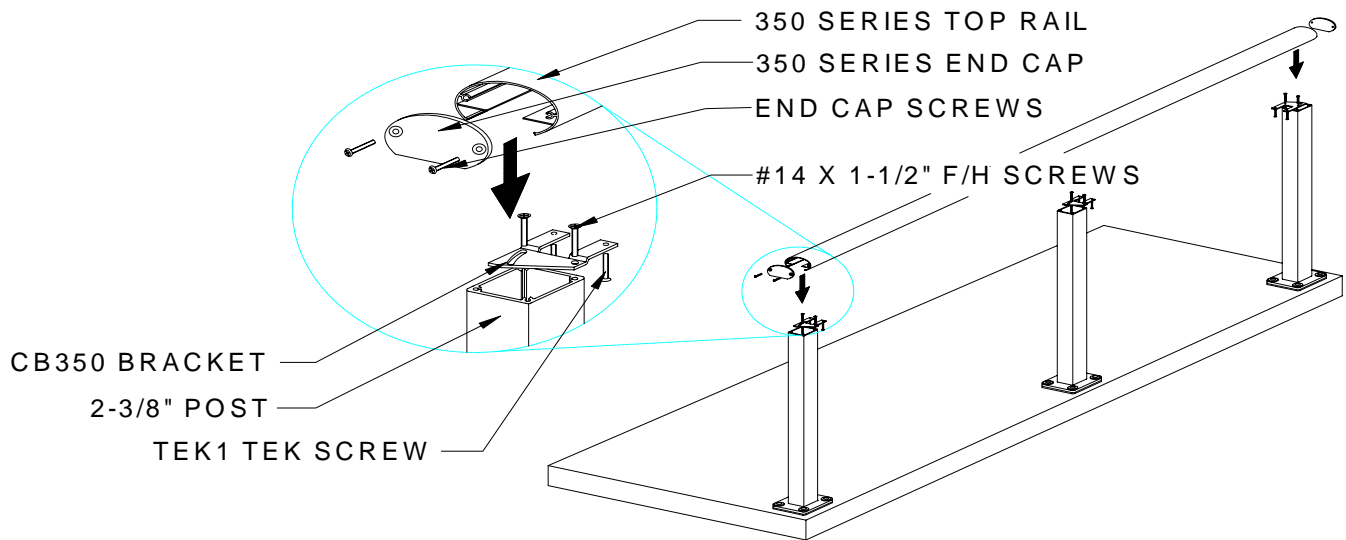

**200, 300, 350 & 400 Series Top Infill and Bottom Rail Installation:**

For glass infills use deep Top and Bottom Rails.



For Picket Infills use shallow Top and Bottom Rails.



**Top and Bottom Rail Installation for Glass:**

Cut rails to length between Posts.

Snap fit Top Infill into Top Rail.

Press Bottom Rail over Rail Connector Blocks and secure with self-drilling Screws provided.

*Helpful Hints: Use the die line on the bottom leg of the Bottom Rail extrusion as a guide for the Screws.*

*Screws should be approx. 1/2" (12 mm) from the edge of the Post.*

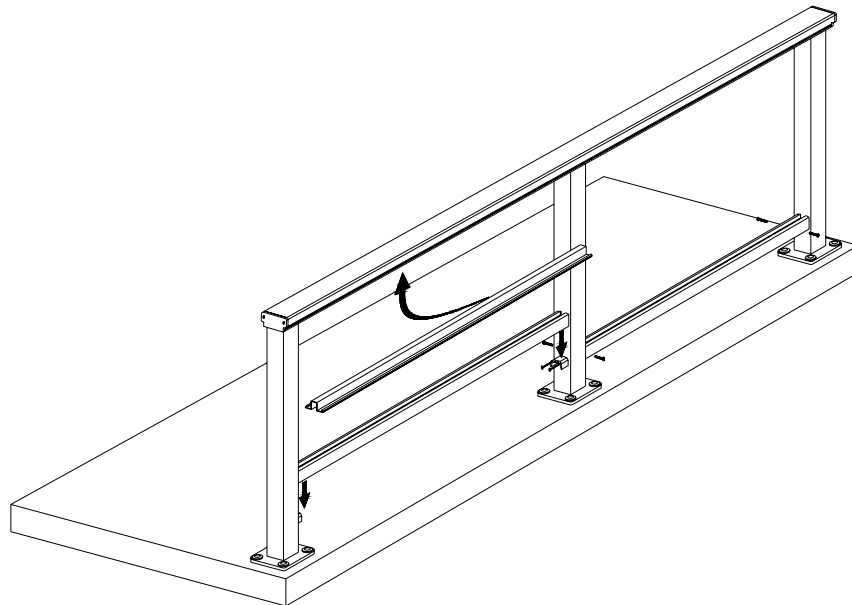

**200, 300, 350 & 400 Glass Installations:**

Cut Top and Bottom Vinyl the same length as the Rails. Press fit the Vinyl into the Rails.

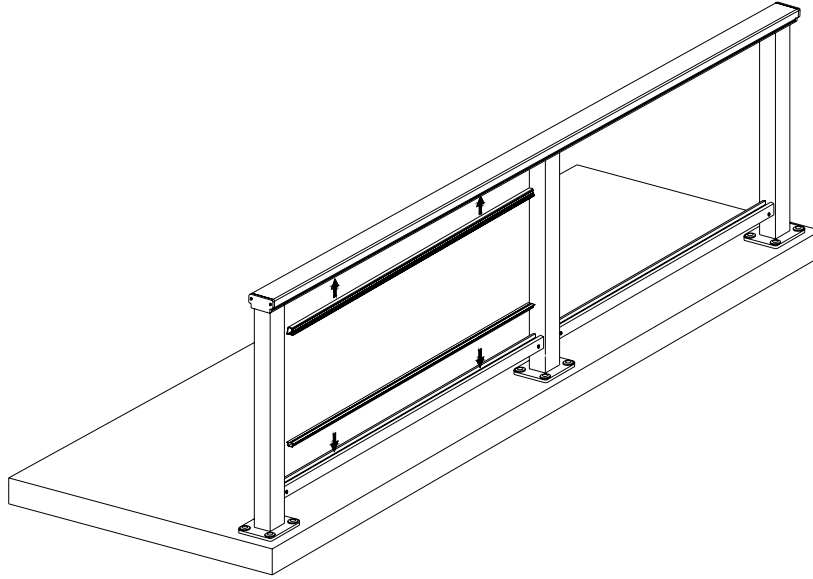

Glass size is determined by the daylight opening.

**Height:** Daylight Opening plus 3/4" (19 mm).

**Width:** Daylight Opening minus 3" (76 mm). (1-1/2" [38 mm] each side).

To install glass, insert fully into the Top Vinyl, then align the bottom edge with the Bottom Vinyl and press the glass down into the Vinyl.

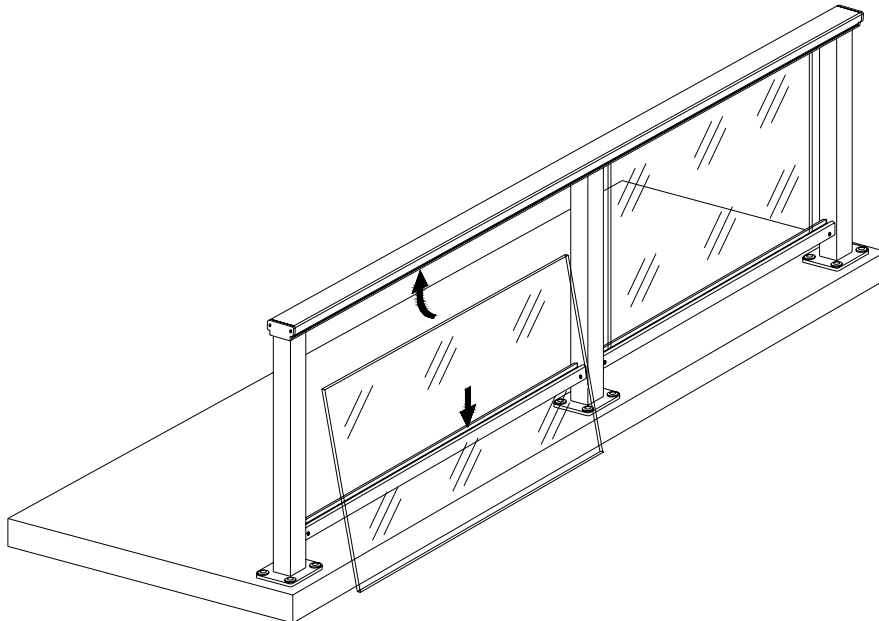

**200, 300, 350 & 400 Picket Assemblies:**

Cut Top and Bottom Infill extrusion to length.

Drill 1/4" (6 mm) diameter holes at 3-7/8" (98 mm) centers in both Top and Bottom Rails

Cut Pickets to desired length and secure to Top and Bottom rails with screws provided.

*Helpful Hints: C.R. Laurence offers several standard pre-assembled Picket Panels, and can make custom sizes as required. This will save considerable time on the job site.*

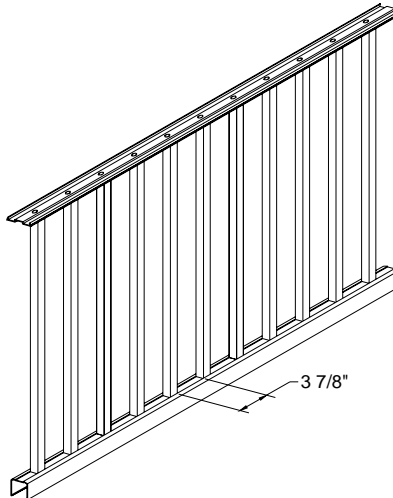

**200, 300, 350 & 400 Picket Installations:**

Raise Picket assembly up into the Top Rail. Slide panel so that the Bottom Rail fits over Rail Connector Blocks. Press assembly down and move to vertical. Push up and clip fit Top Infill into Top Rail. Secure Bottom Rail to Rail Connector Blocks with self-drilling Screws Cat. No. TEK1 provided.

